

**Fahrgestell L 2 H 143 mit luftgekühltem Ottomotor**

- 1 Motorhaube
- 2 Schaltbrett
- 3 Wechselgetriebe
- 4 Lenkrad
- 5 Vorratsrad

- 6 Stützachse
- 7 Vorratsrad
- 8 Gelenkwelle
- 9 Rahmen
- 10 Zusatzgetriebe

- 11 Mittelachsenantrieb
- 12 Hinterfedern
- 13 Hinterachsenantrieb
- 14 Protzhakenkupplung

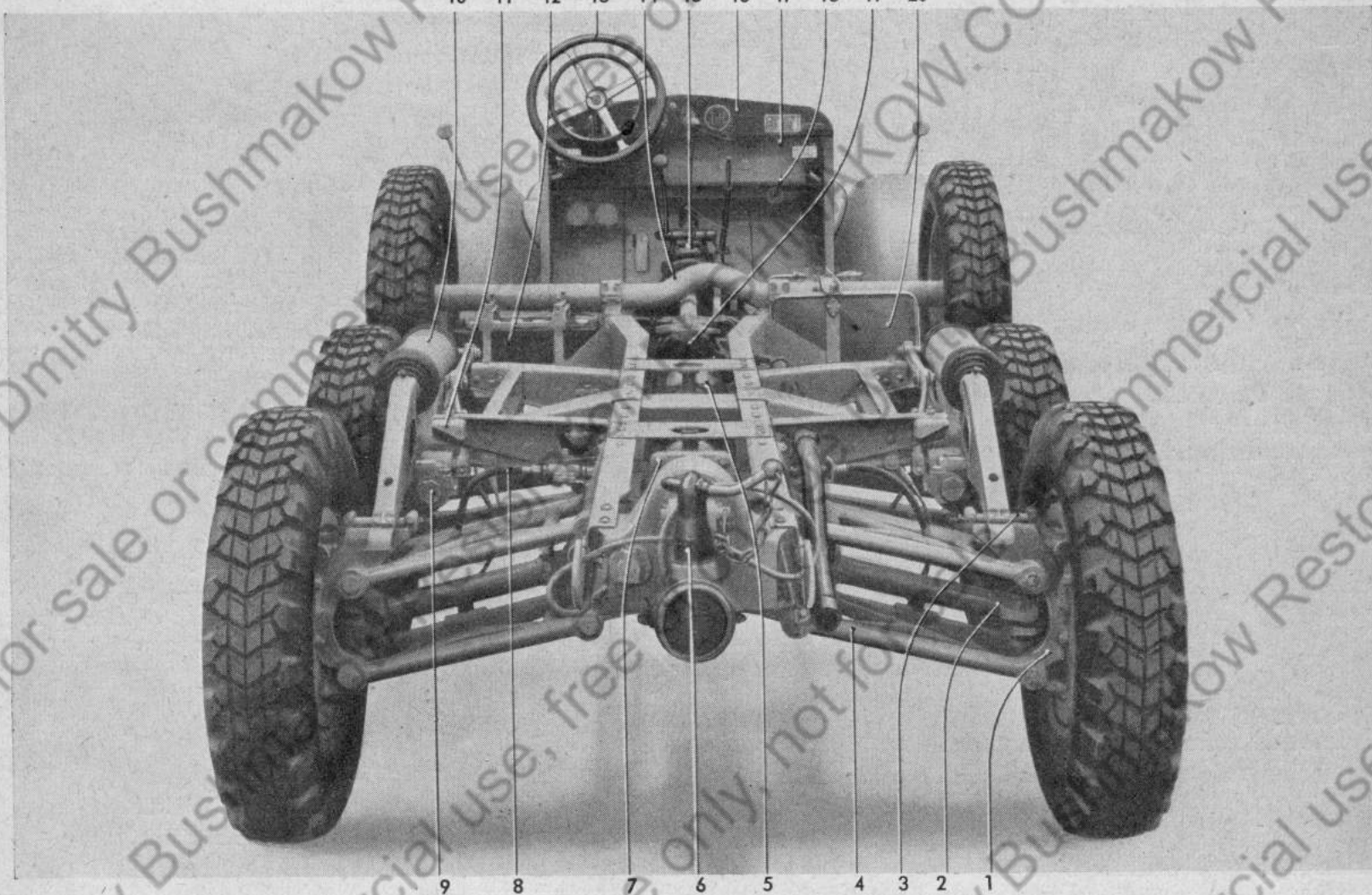

Ansicht von oben auf das Fahrgestell

- |                      |                                 |                             |
|----------------------|---------------------------------|-----------------------------|
| 1 Radhalter          | 8 Bremsschlauch                 | 15 Wechselgetriebe Gb 35 bL |
| 2 Hinterachswellen   | 9 Stoßdämpfer                   | 16 Schaltbrett              |
| 3 Tragrolle          | 10 Hinterfeder (Schraubenfeder) | 17 Hilfskraftstoffbehälter  |
| 4 Querlenker         | 11 Achsanschlag                 | 18 Dreiweghahn              |
| 5 Mittelachsantrieb  | 12 Sammler                      | 19 Zusatzgetriebe G G 35    |
| 6 Protzhakenkupplung | 13 Lenkrad                      | 20 Kraftstoffbehälter       |
| 7 Hinterachsantrieb  | 14 Stützachse                   |                             |

10 11 12 13 14 15 16 17 18 19 20 21 22 23

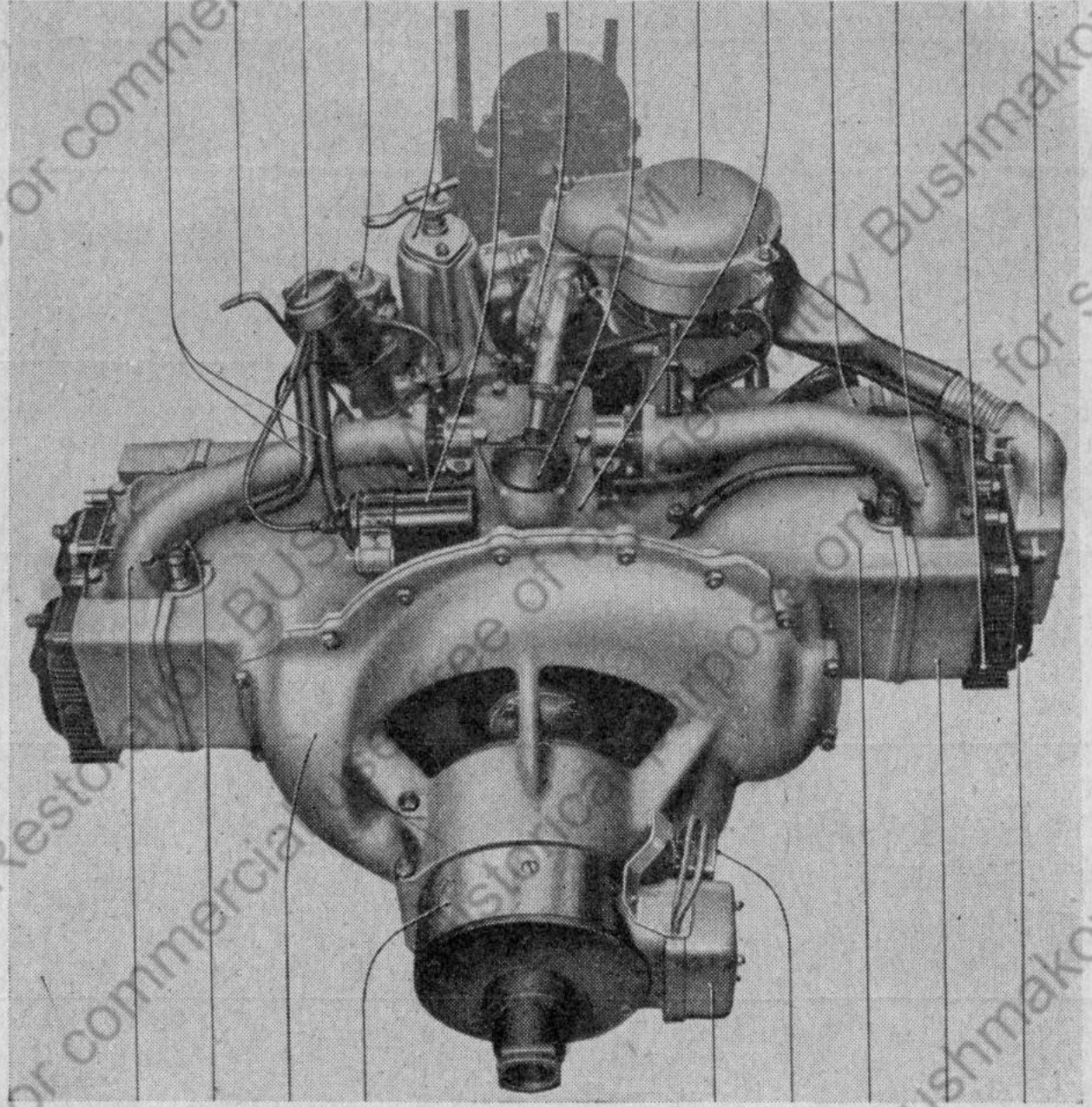

9 8 7 6 5 4 3 2 1

**Motor, Ansicht von oben**

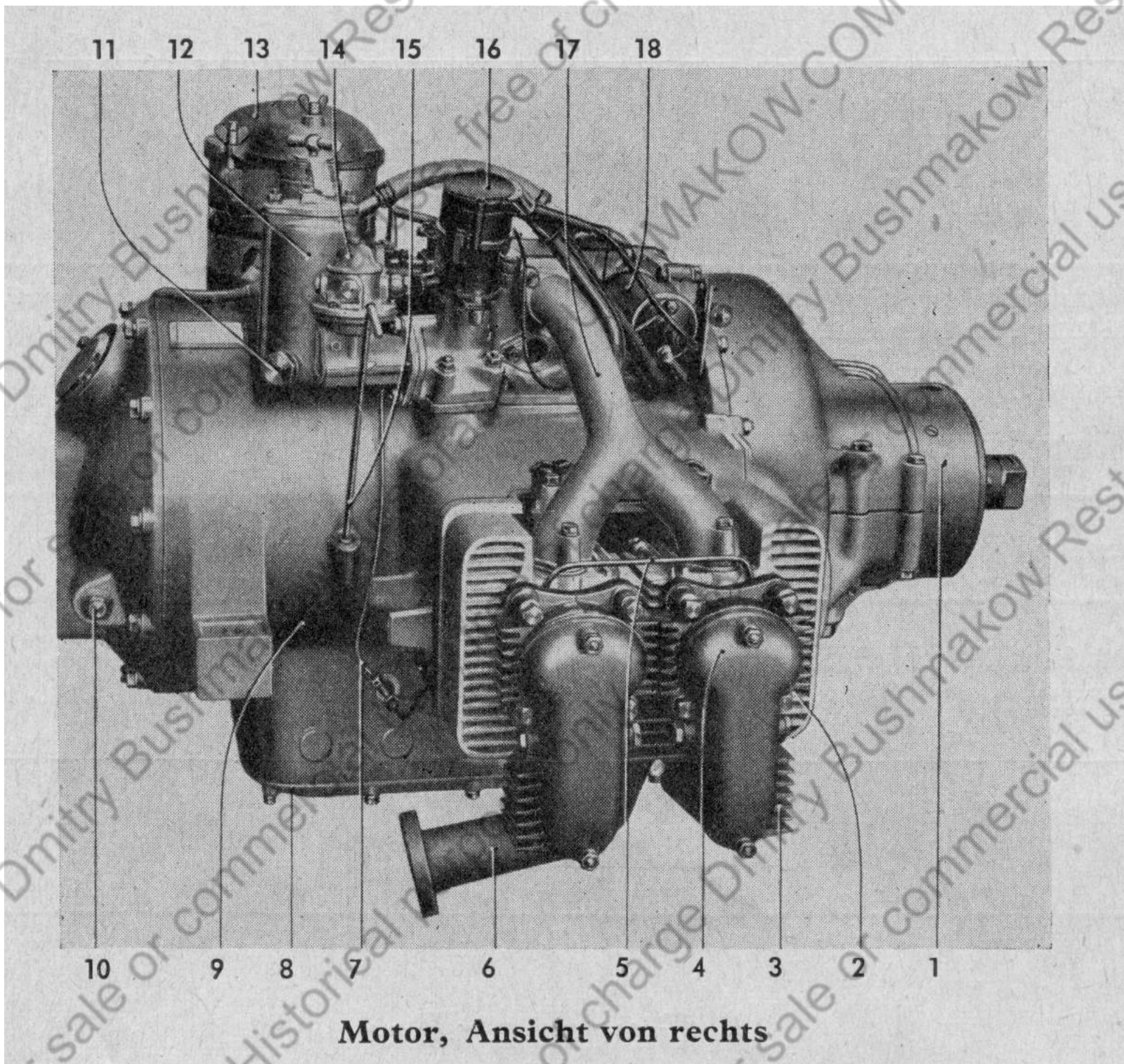

**Motor, Ansicht von rechts**



Bild 1 Lenkgetriebe aushauen



7 6 5 4 3 2 1

**Bild 2 Motor ausbauen**

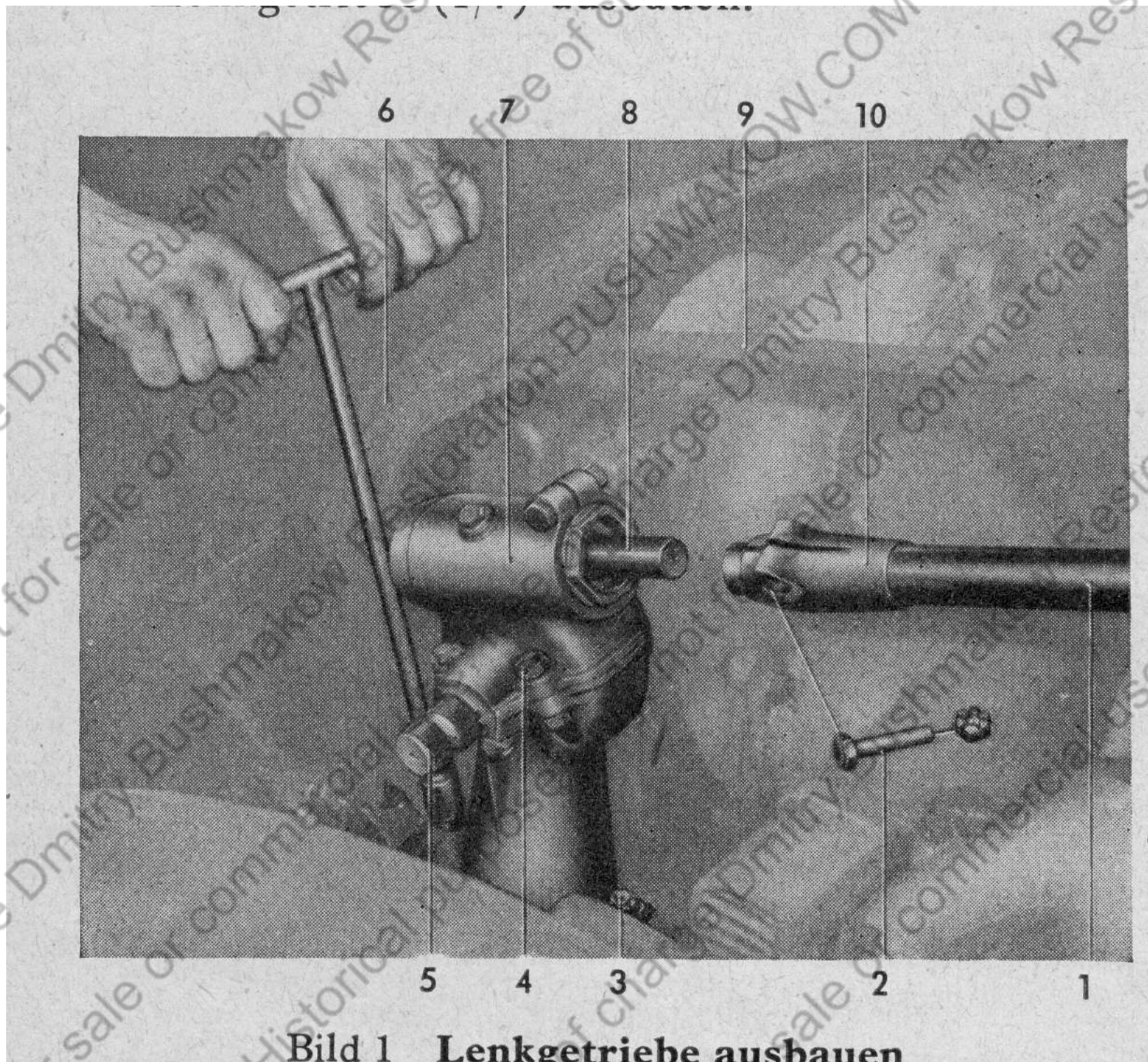
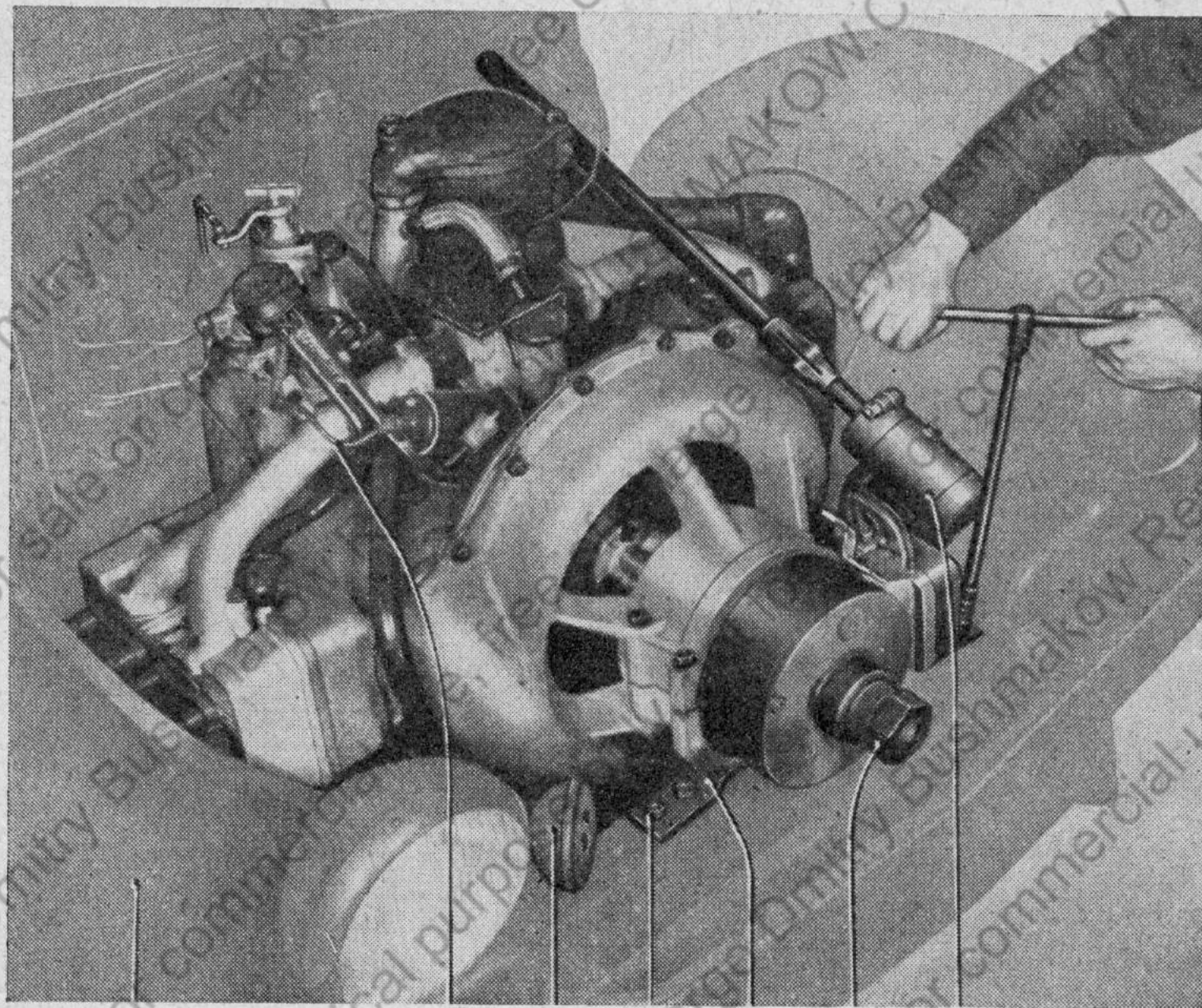
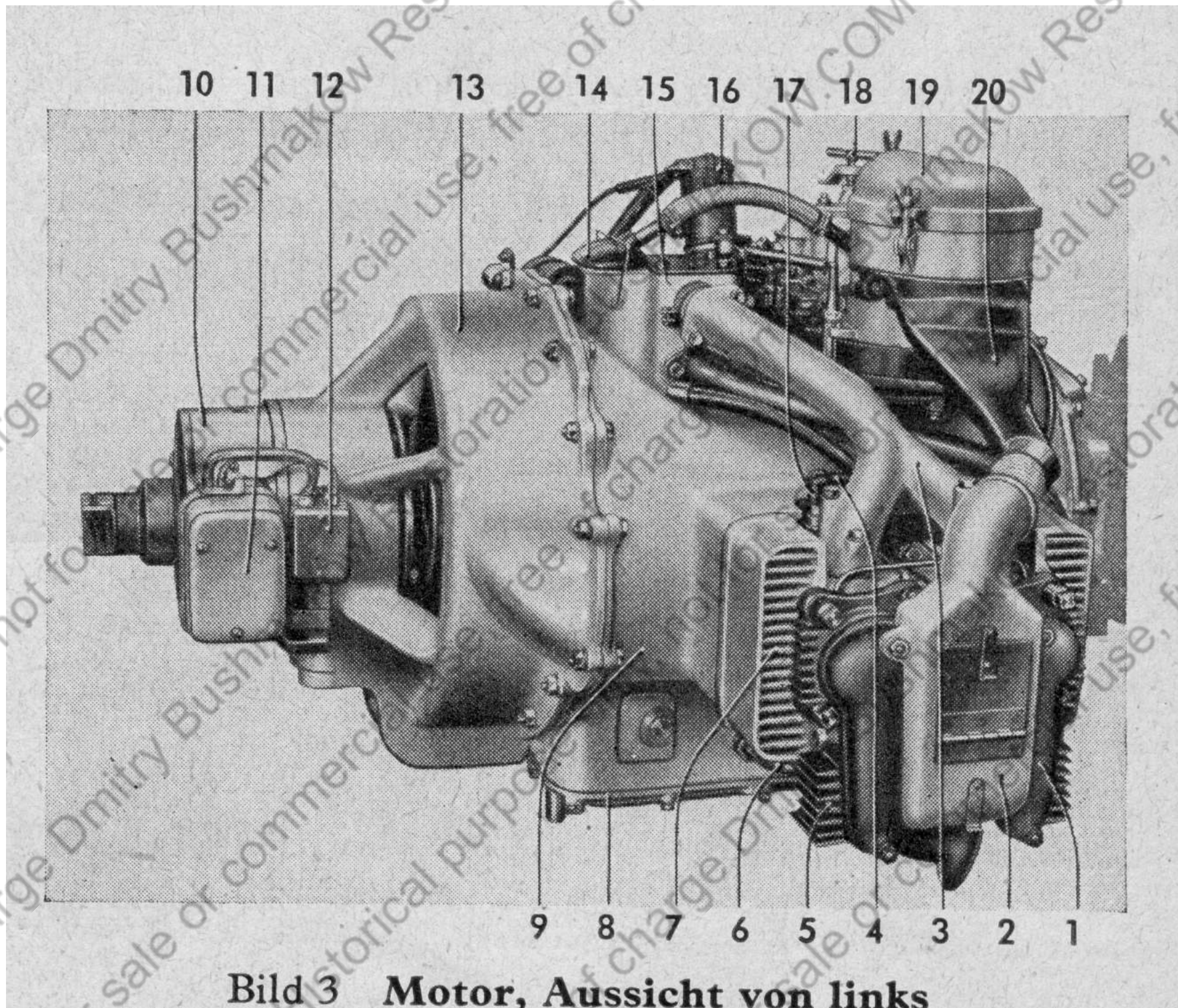

**Bild 3 Motor, Aussicht von links**

10 11 12 13 14 15

16

17

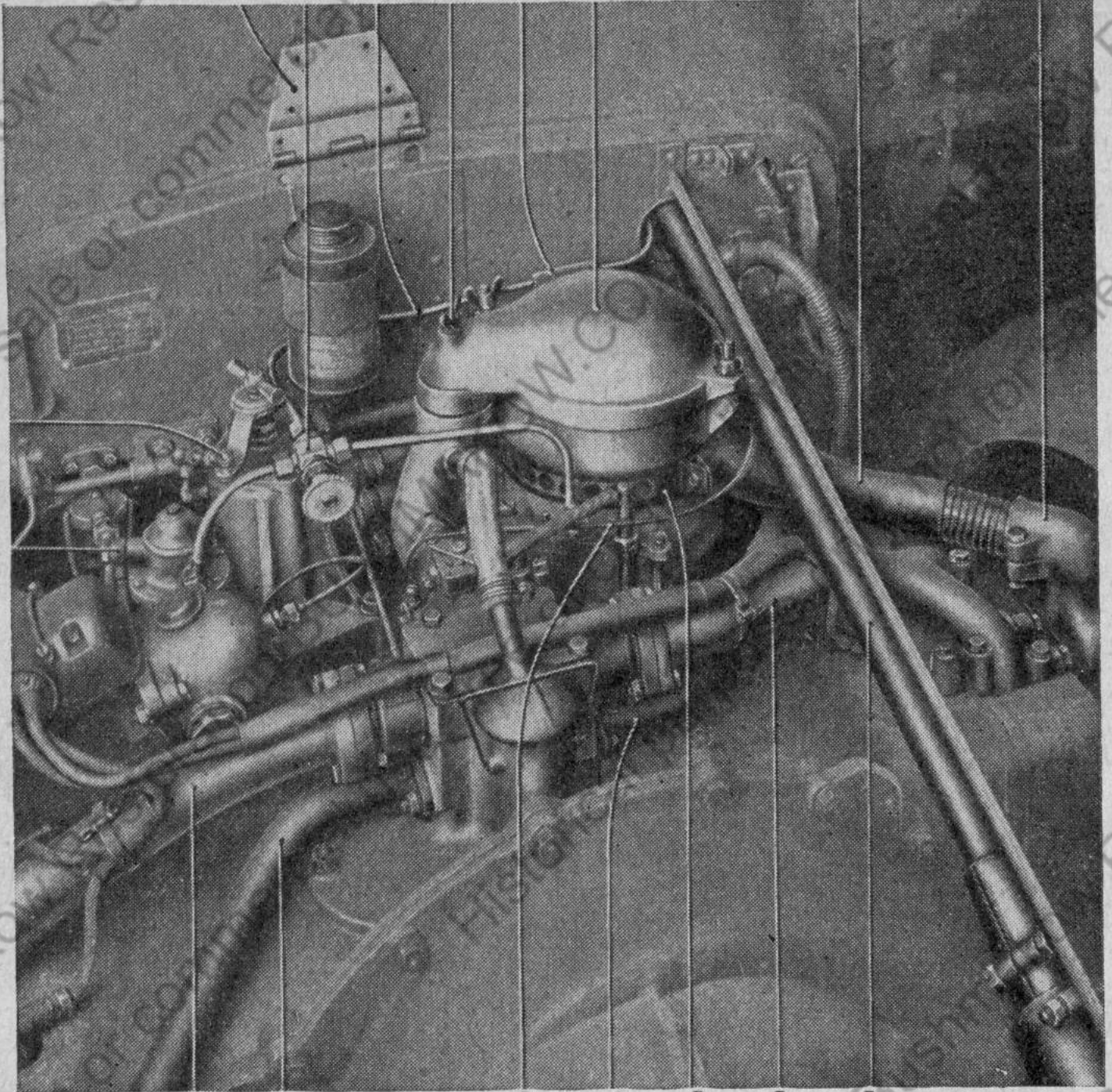

7

6

5

4

3

2

1

Bild 4 Motor



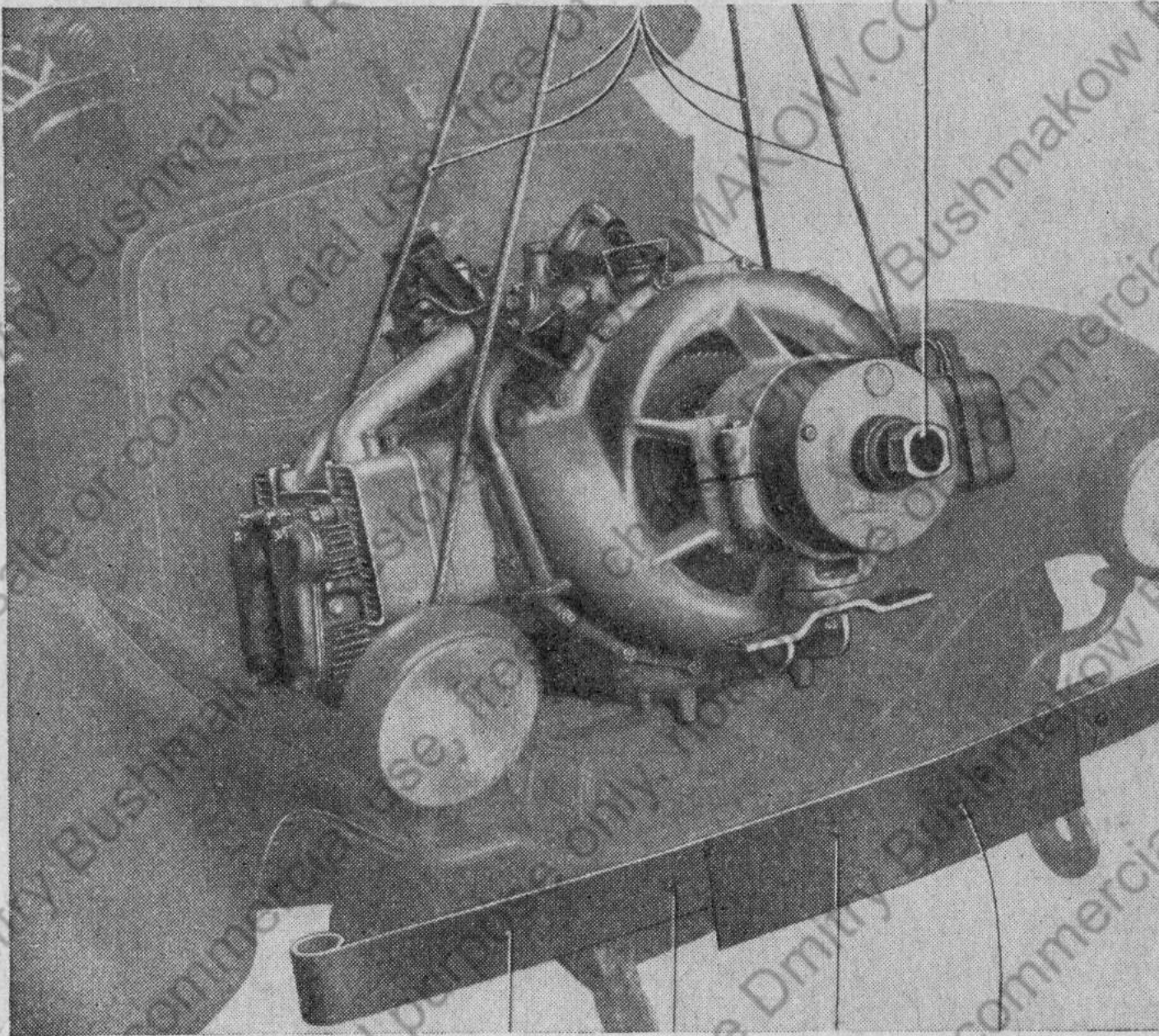

**Bild 5 Motor aus dem Fahrgestell heben**



Bild 6 Fußblech



1.1

**Bild 7 Wechselgetriebe mit Getriebeflansch ausbauen**

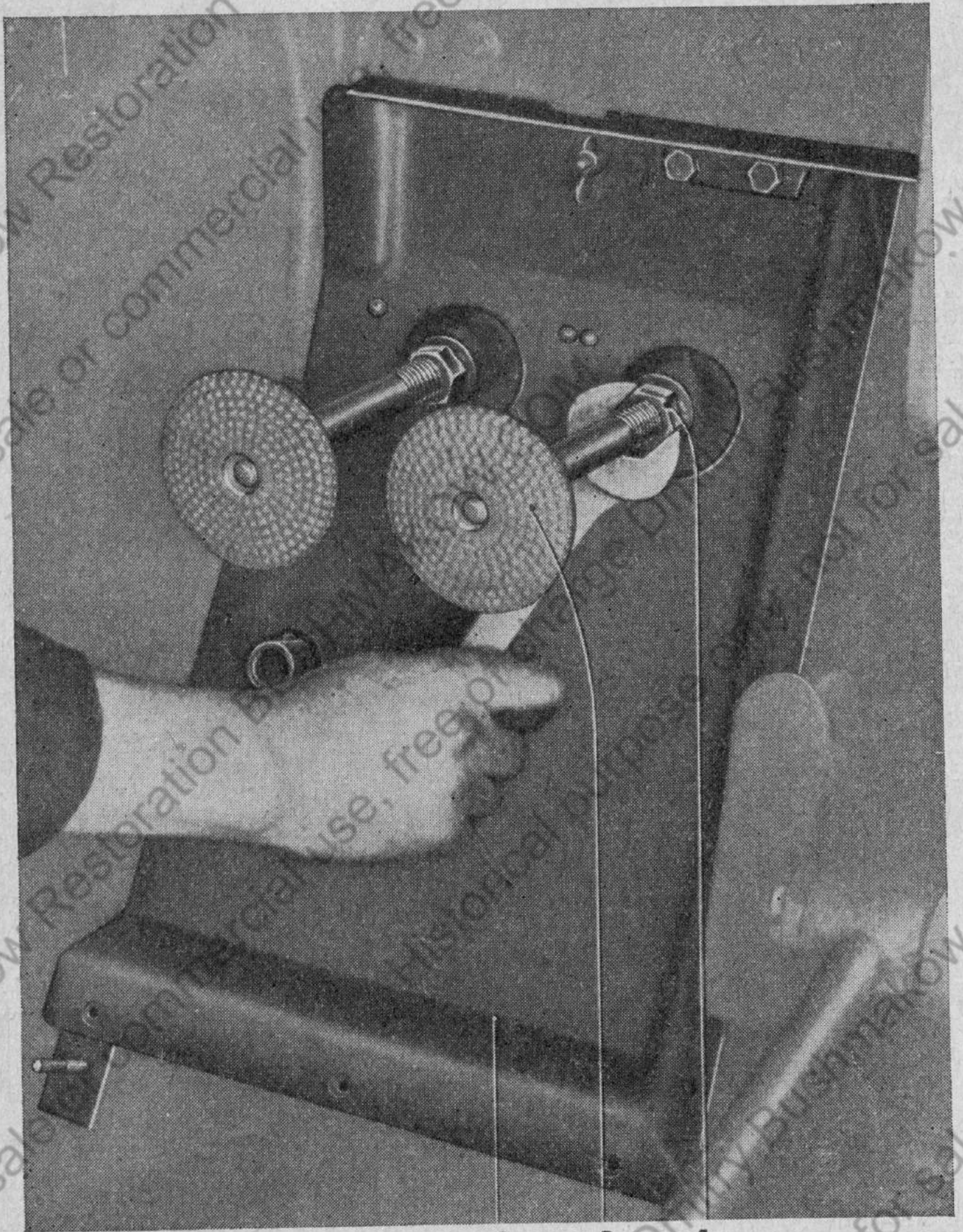
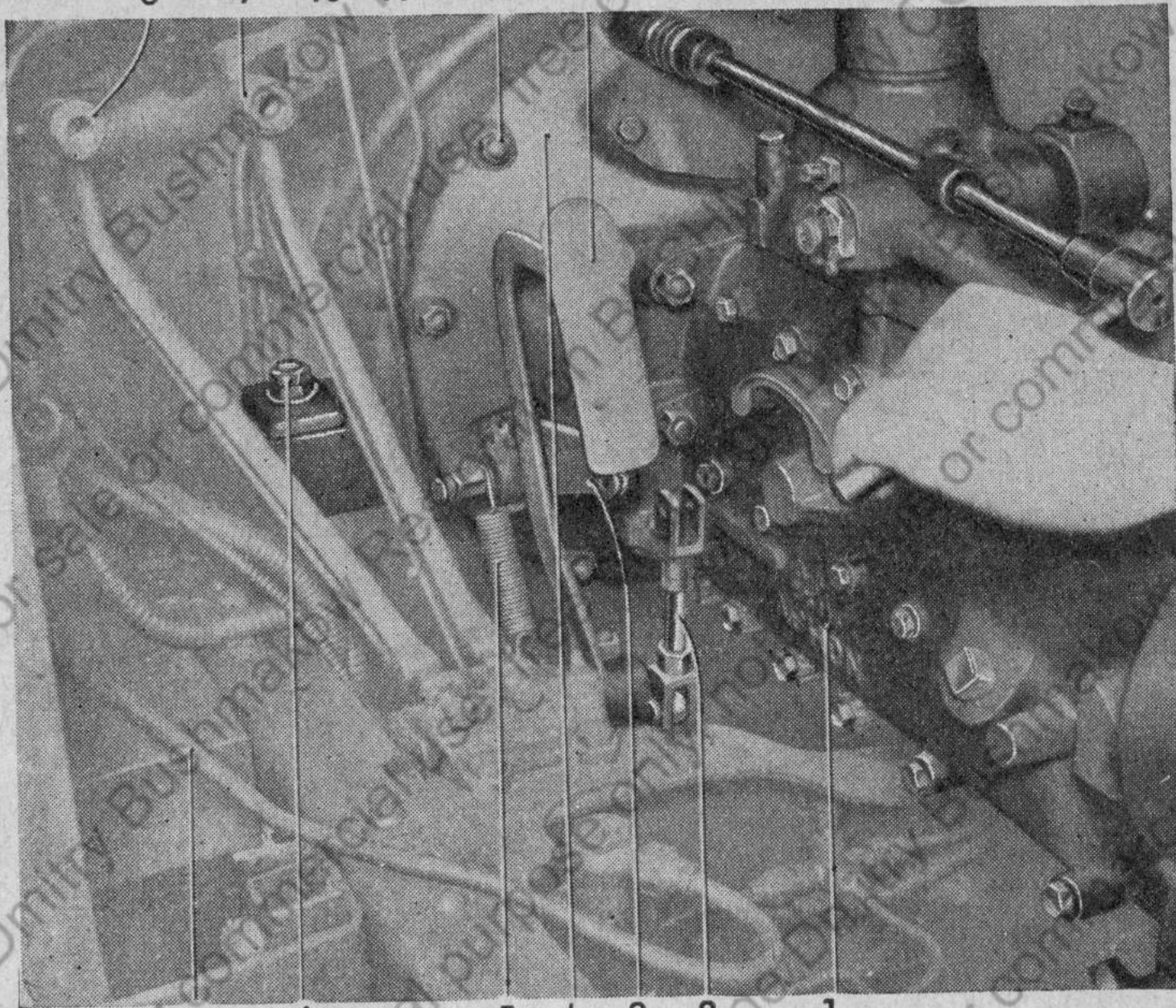
1 Wechselgetriebe

7 Ölleitung vom Ölbehälter



Bild 8

## Wechselgetriebe ohne Getriebeflansch ausbauen

1 Zusatzgetriebe

6 Wechselgetriebe

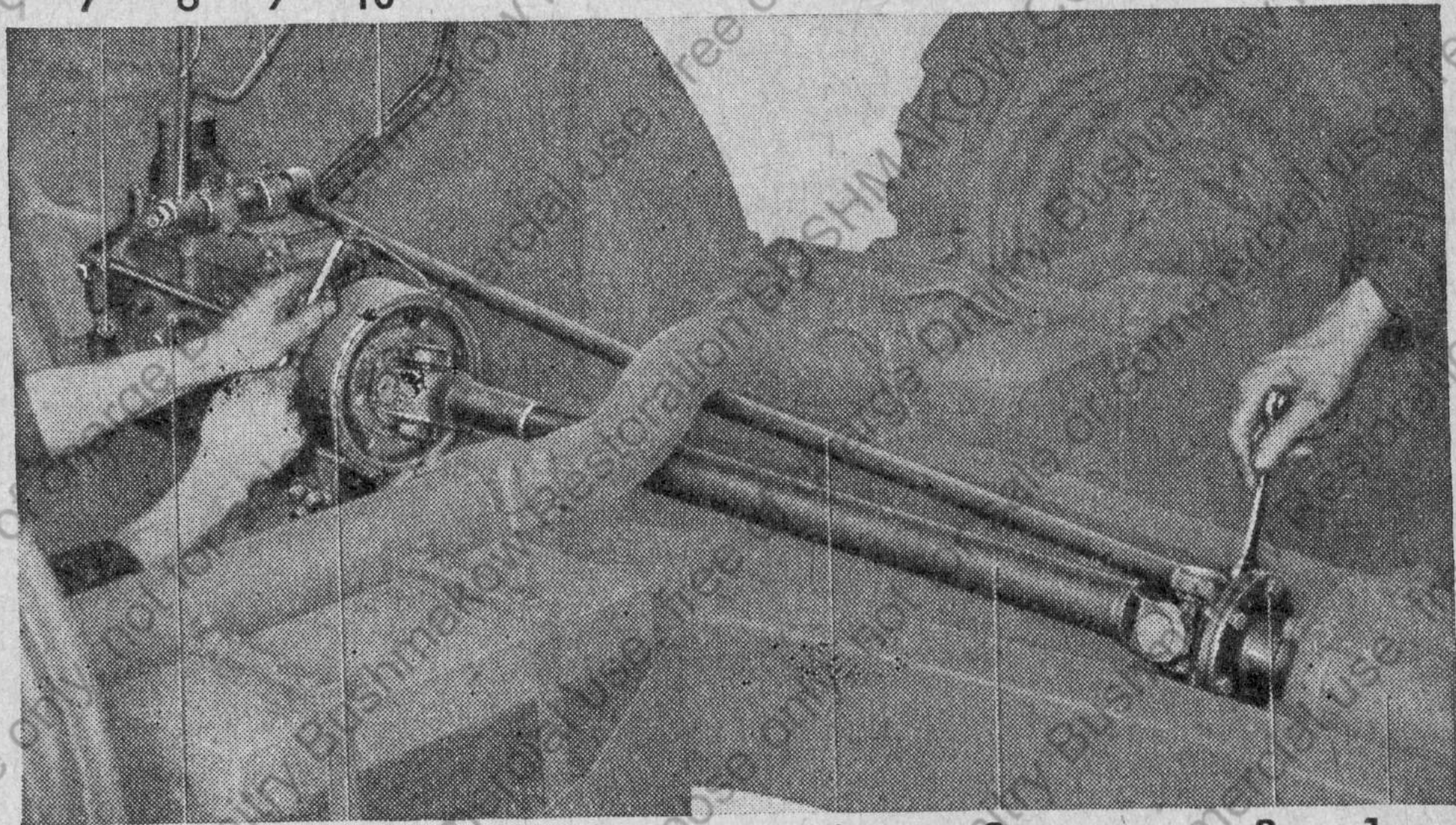
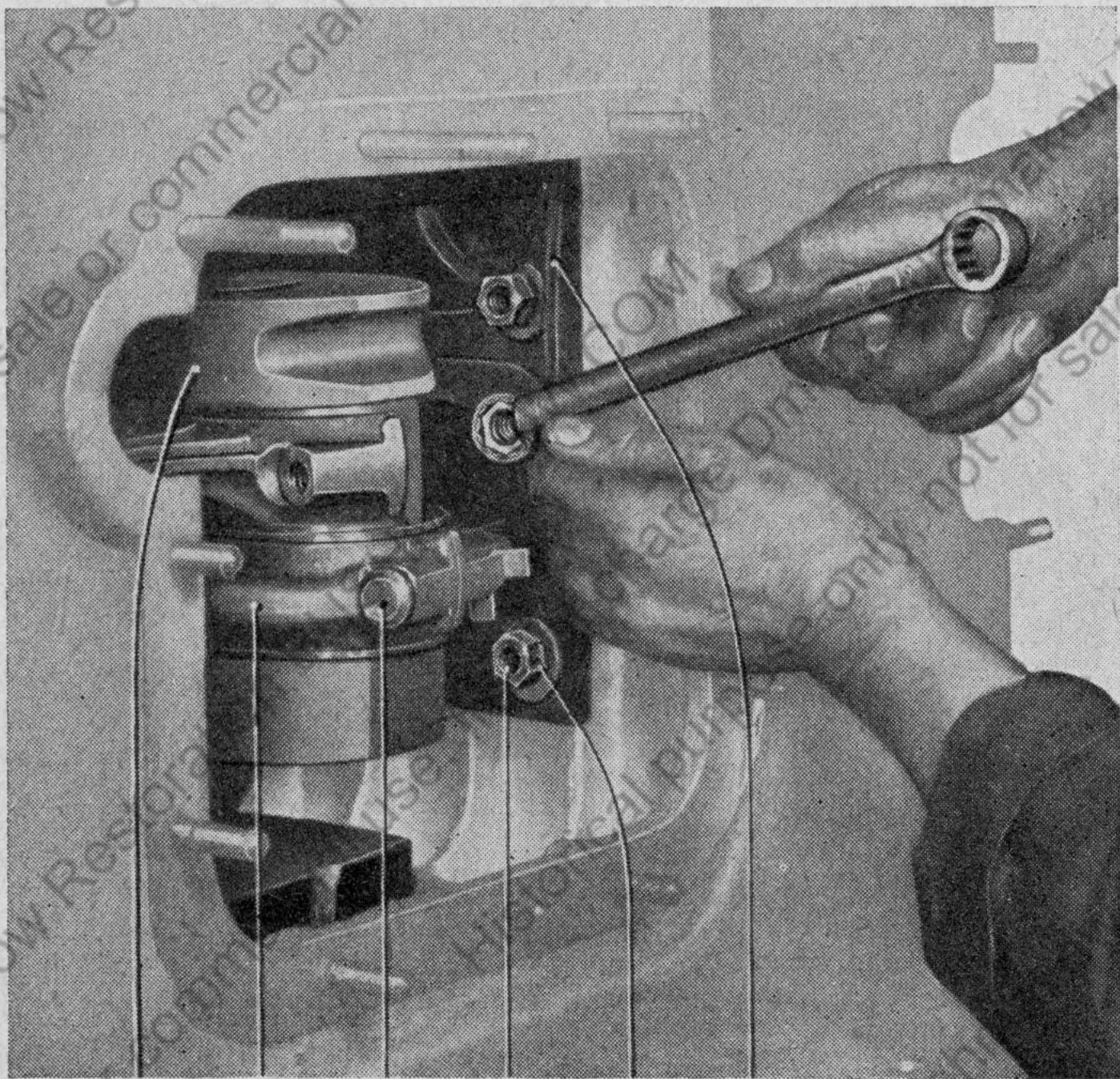

6 5 4 3 2 1

**Bild 9 Zylinder ausbauen**



Bild 10

**Zylinder mit Kolben und Pleuelstange ausbauen**

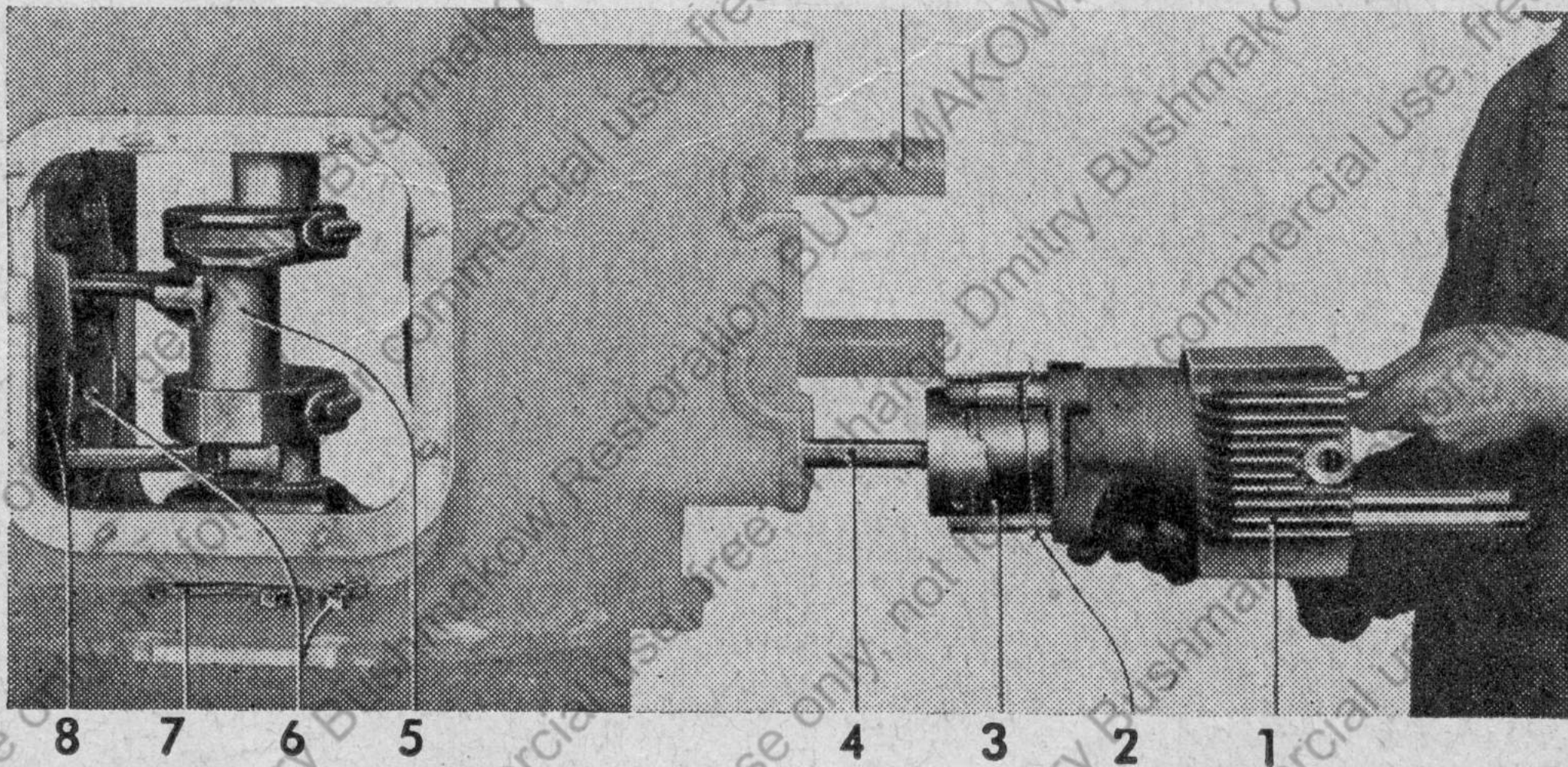
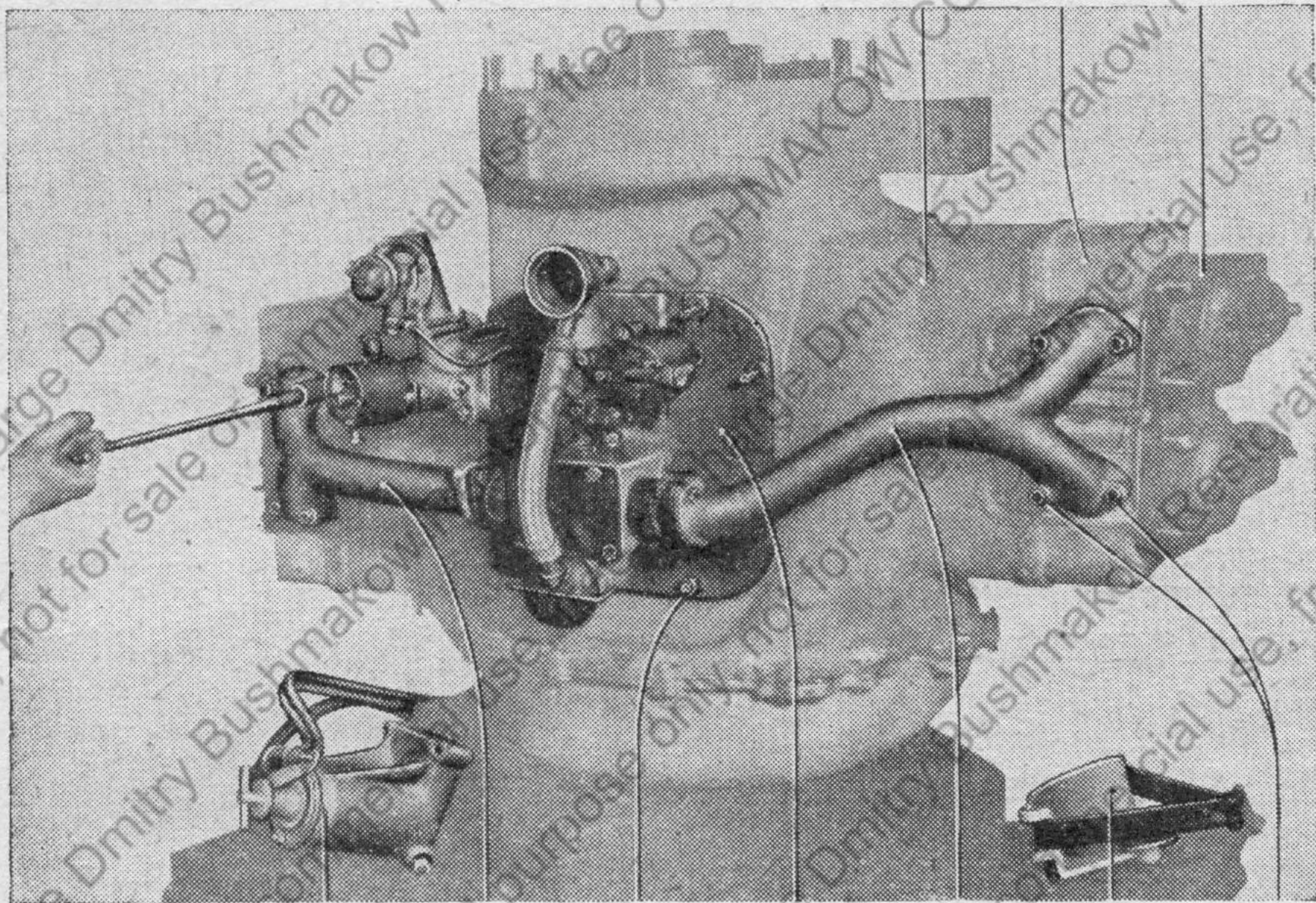

**Bild 11 Oberen Deckel ausbauen**

1 Schrauben zum

3 Linkes Saugrohr

8 Kurbelgehäuse

16 17 18 19

20 21 22 23

24 25 26

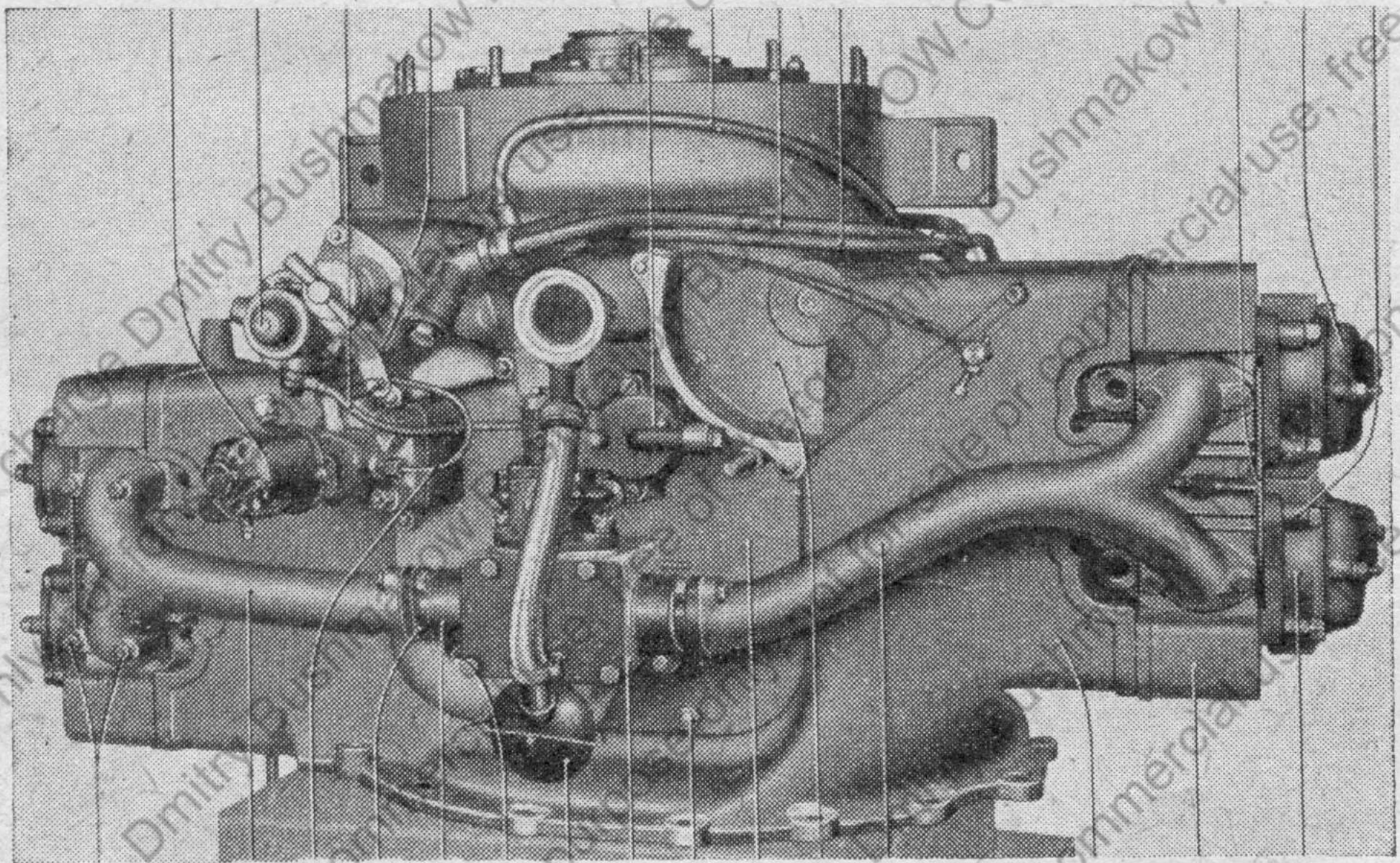

15

14

13

12

11

10

9

8

7

6

5

4

3

2

1

**Bild 12 Motor (Ansicht)**

1 Ventilhebelgehäuse

16 Zündverteiler



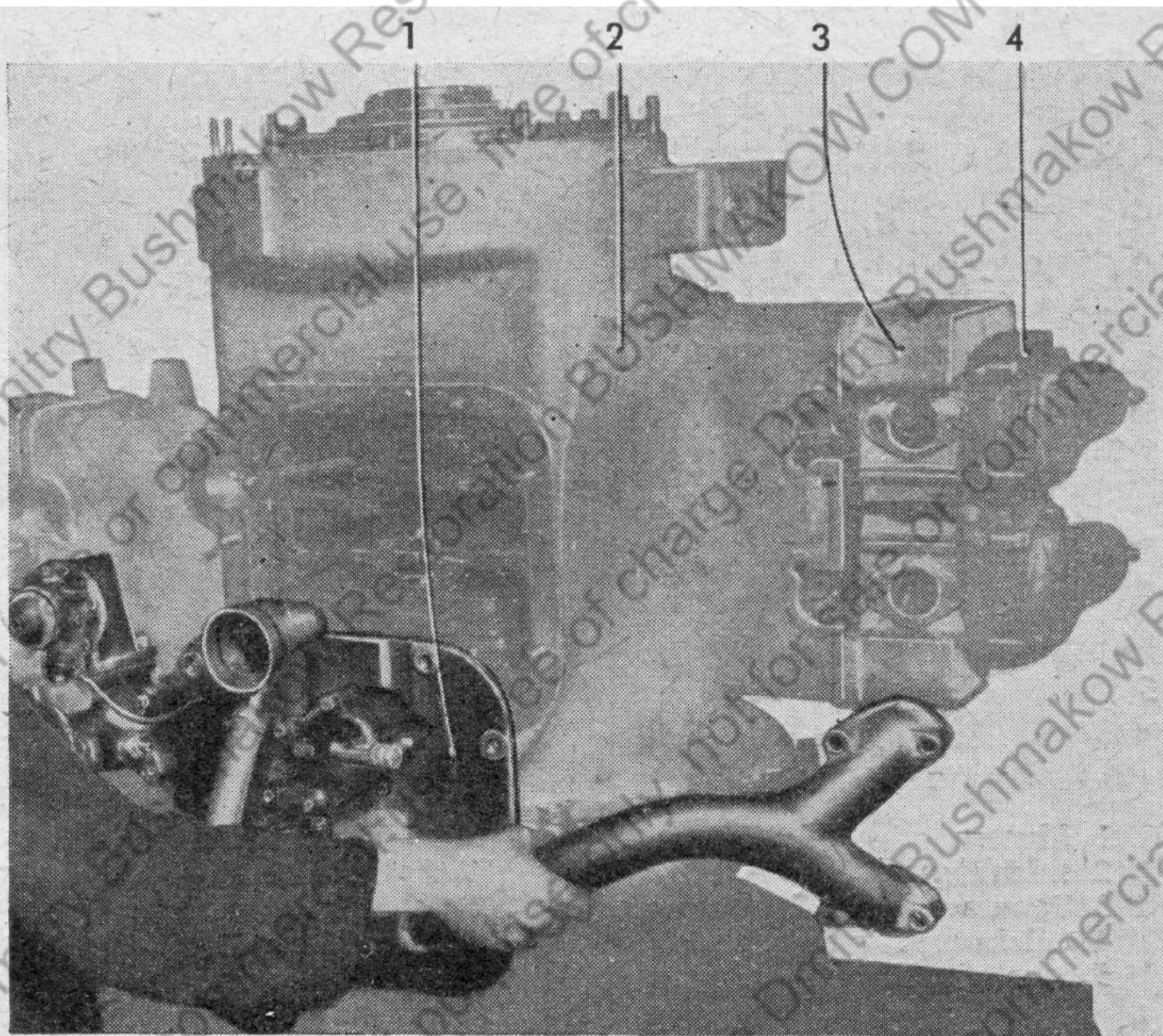

**Bild 13 Oberen Deckel mit Saugrohren abheben**

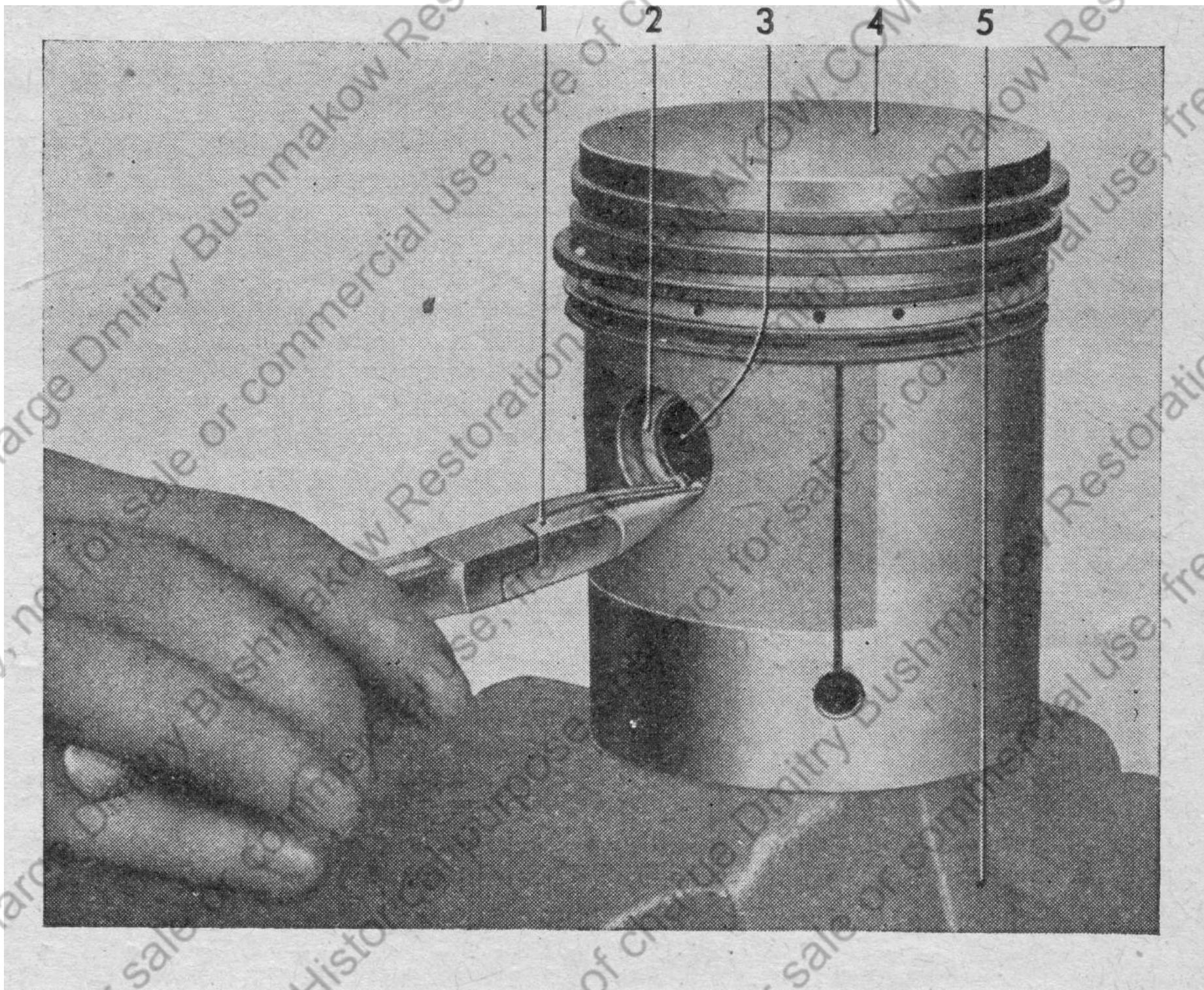

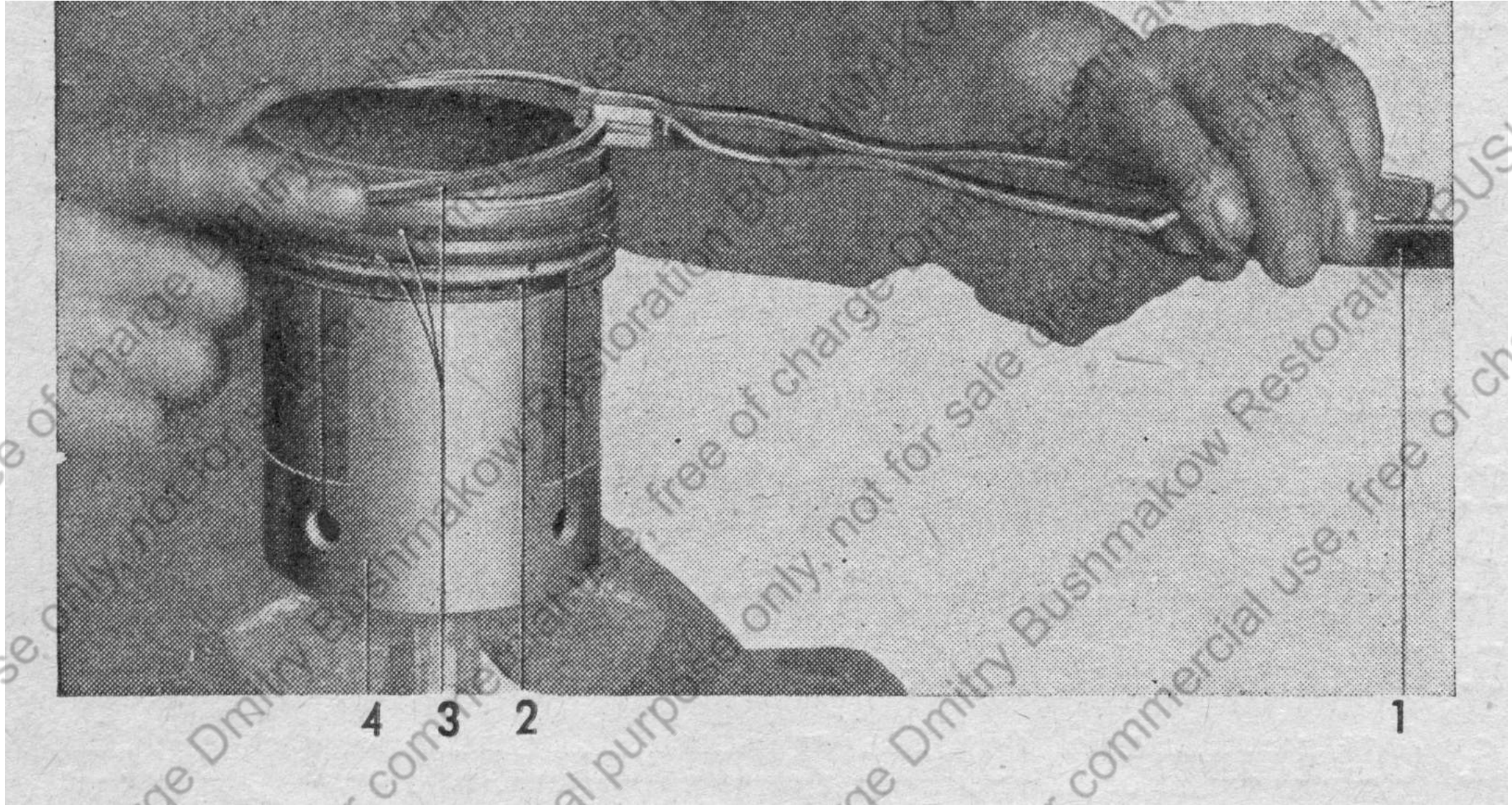

4

3

2

1



Bild 16 Ventilhebelgehäuse ausbauen



6

5

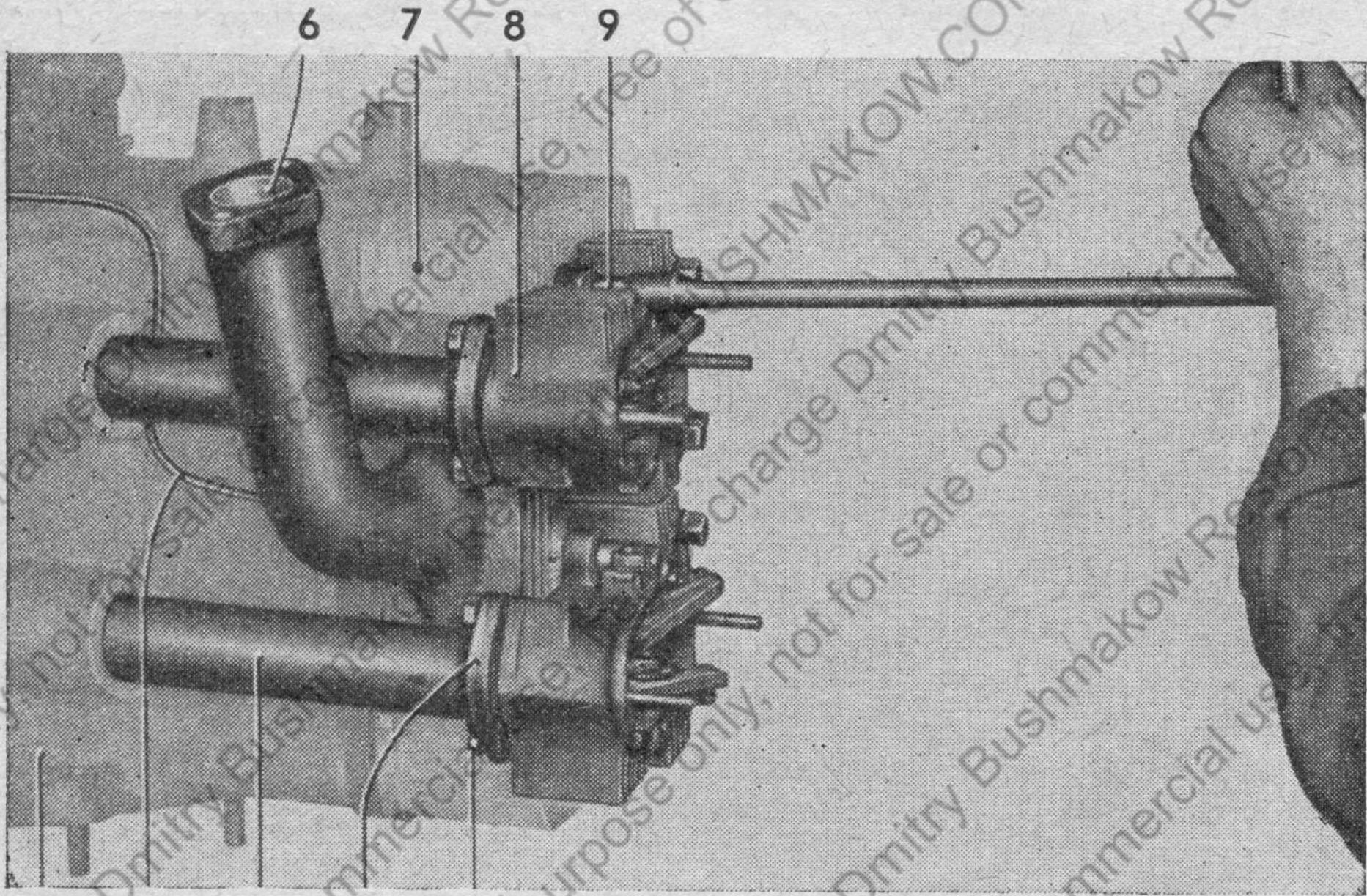
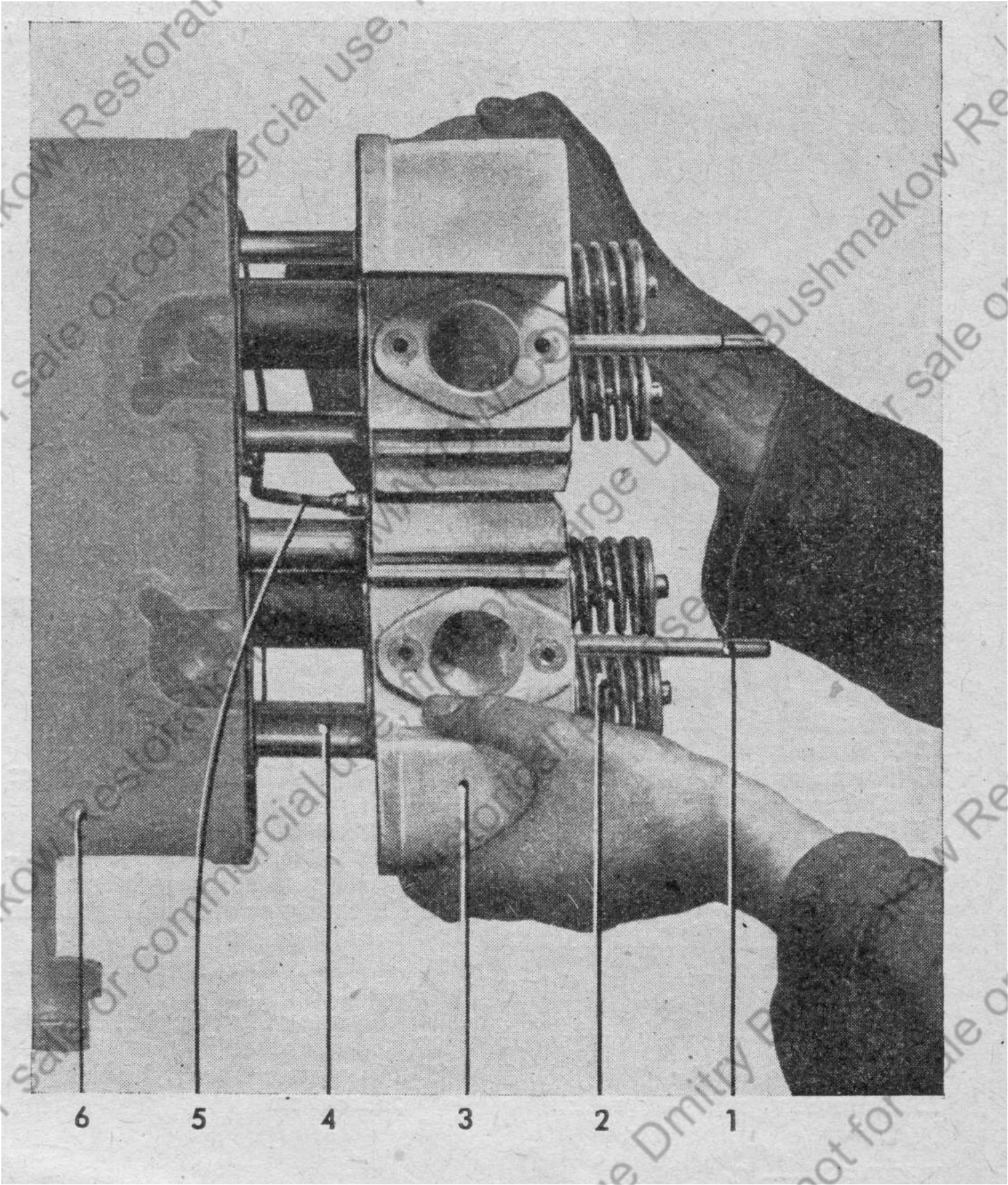
4

3

2

1

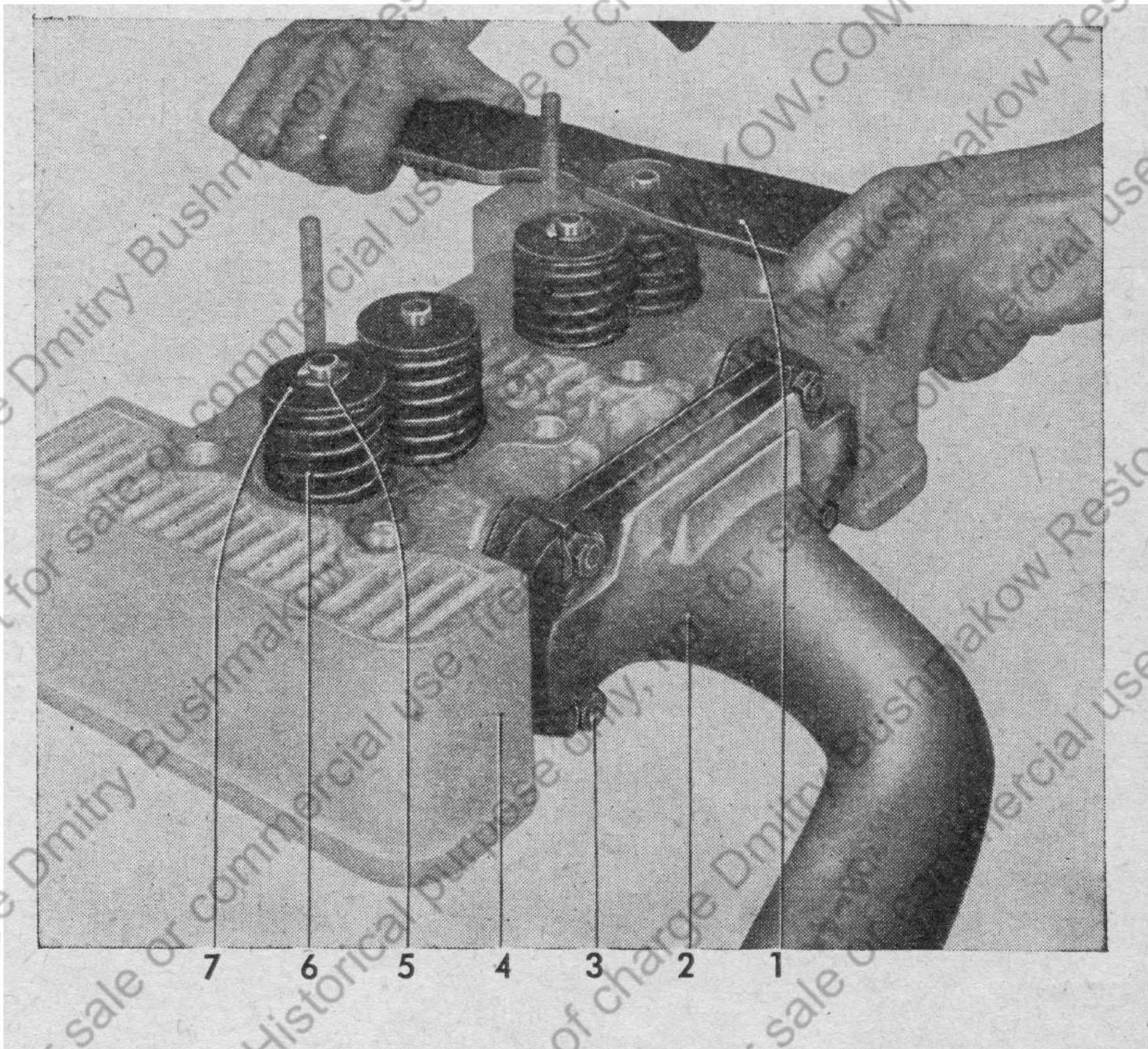

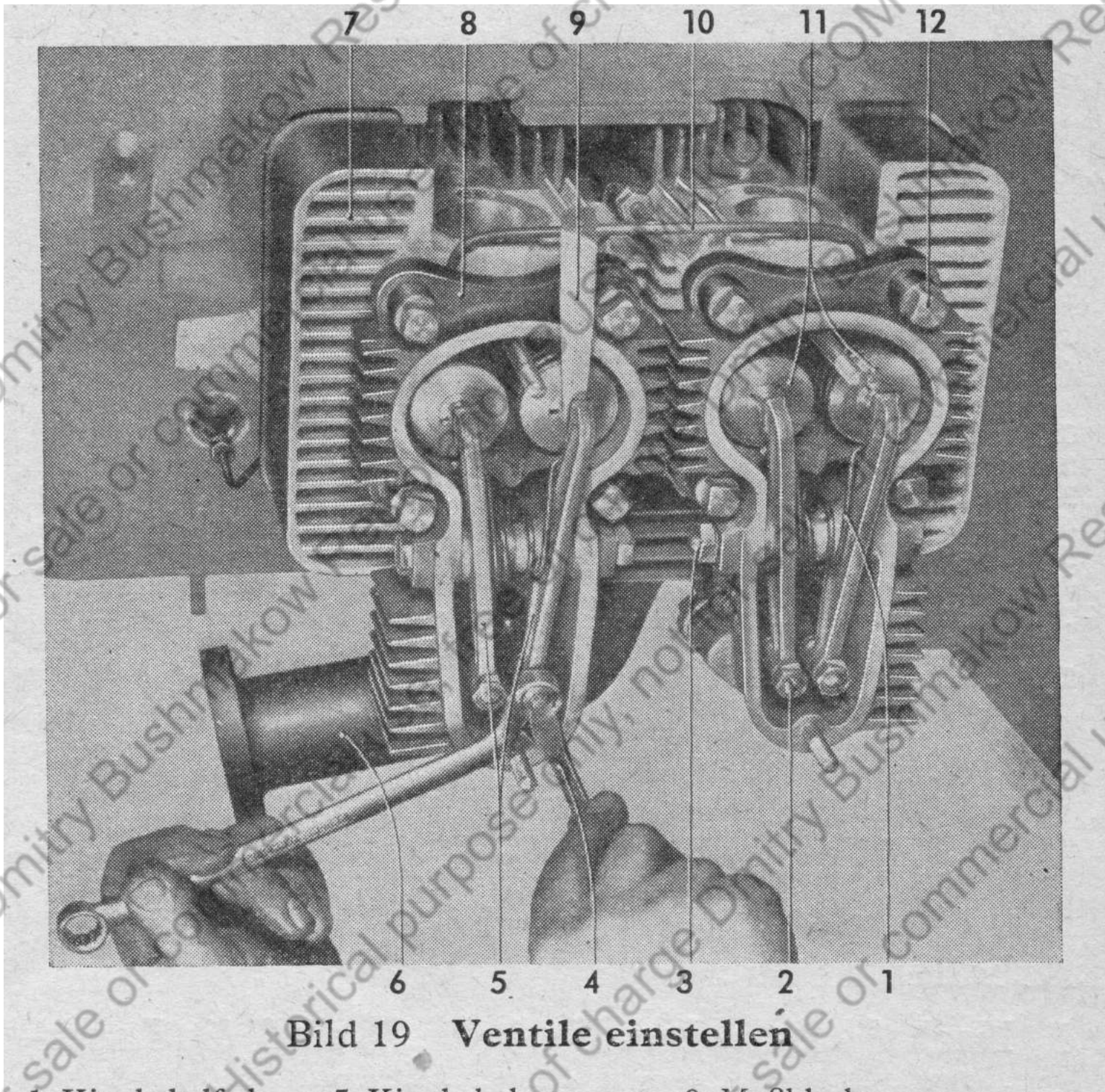

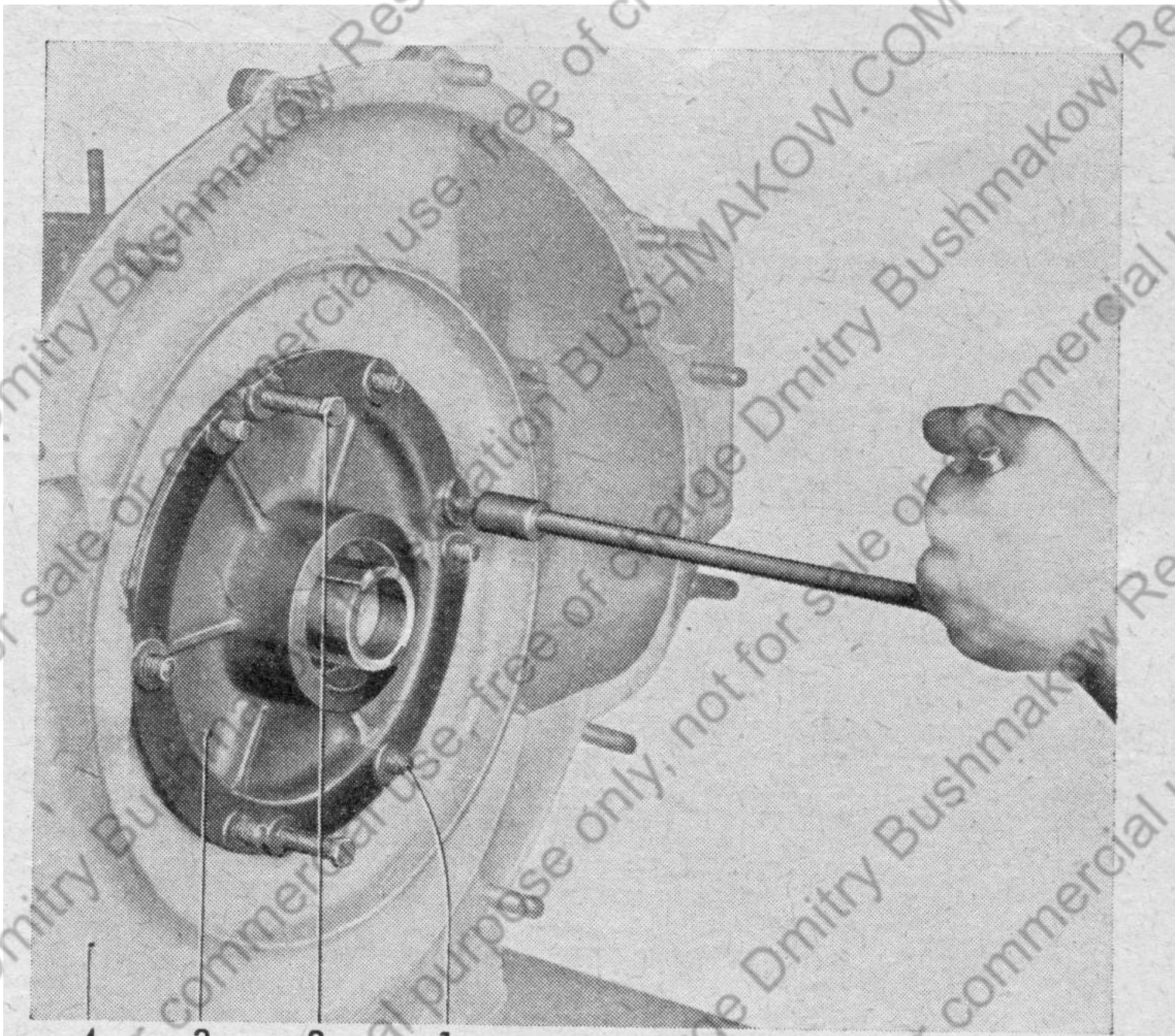

4 3 2 1

**Bild 21 Vorderes Kurbelwellenlager abdrücken**

1 Stiftschraube

3 Vorderes Kurbelwellenlager





Bild 20 **Kurbelwelle ausbauen**

1 Vorderes Kurbelwellenlager

9 Zweitstücker Deckel

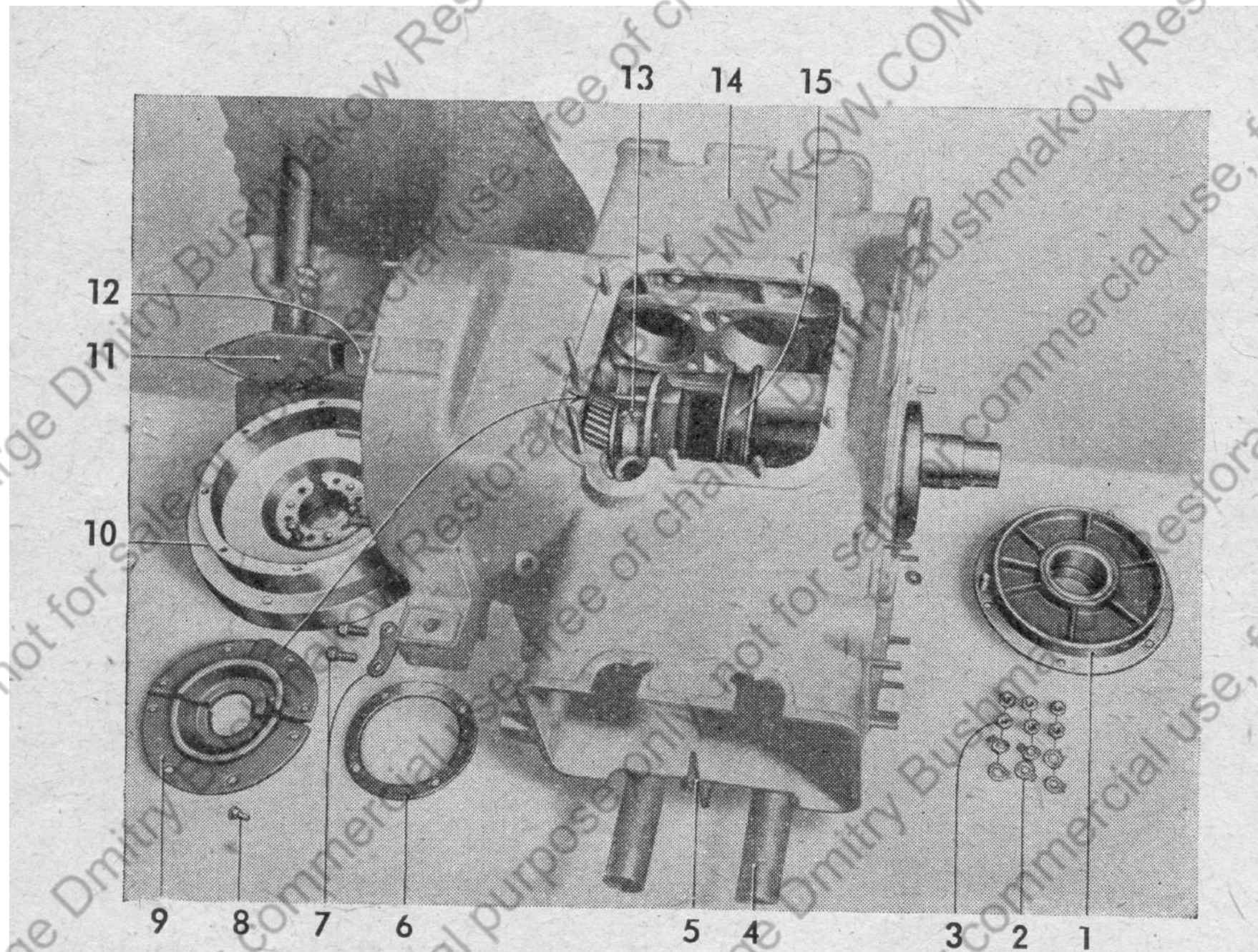

Bild 22 Kurbelwelle einbauen



**Bild 23**    **Vorderes Kurbelwellenlager einbauen**

1. Kurbelgehäuse

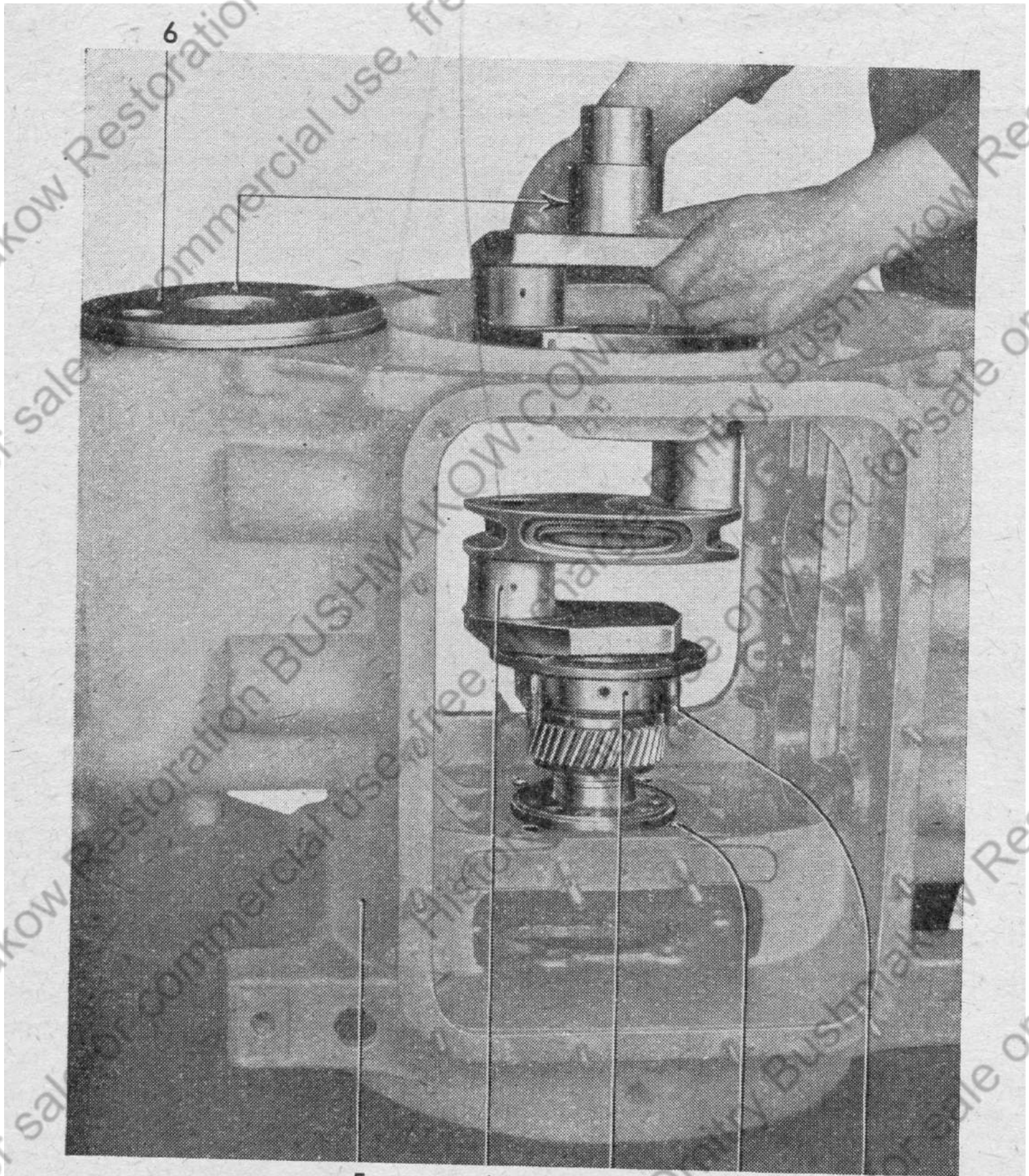
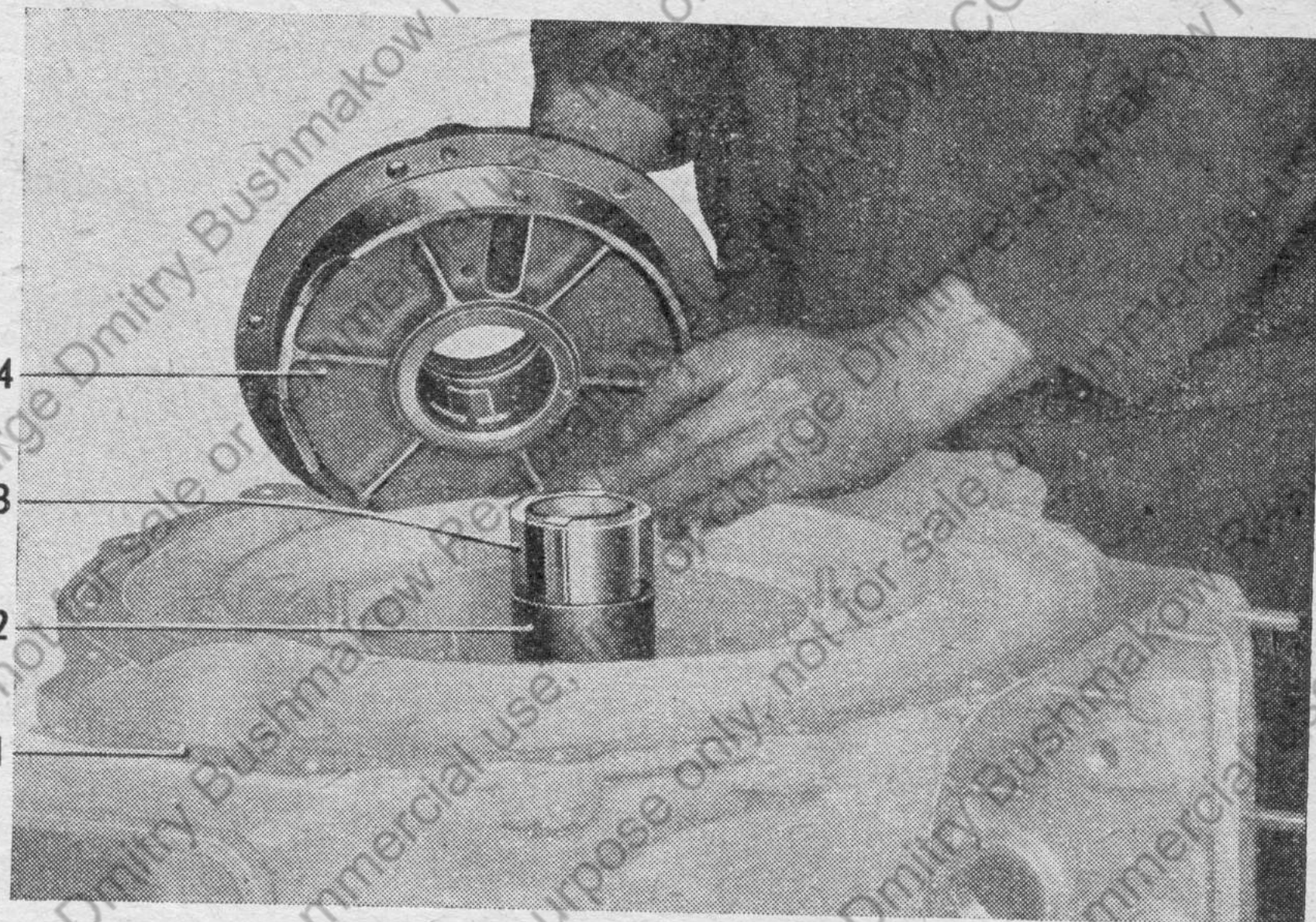
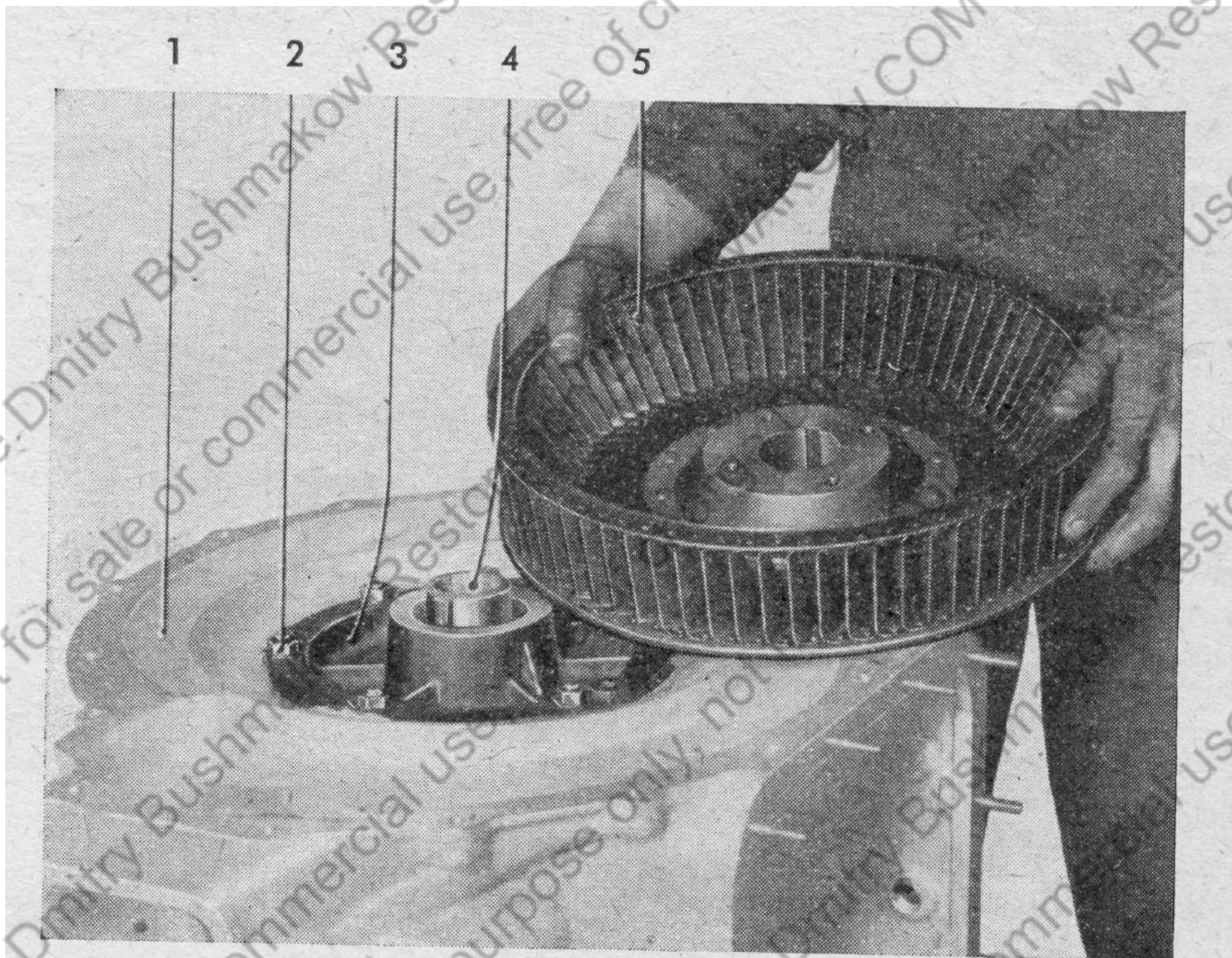

**Bild 24 Lüfter (Windrad) einbauen**

1 Kurbelgehäuse

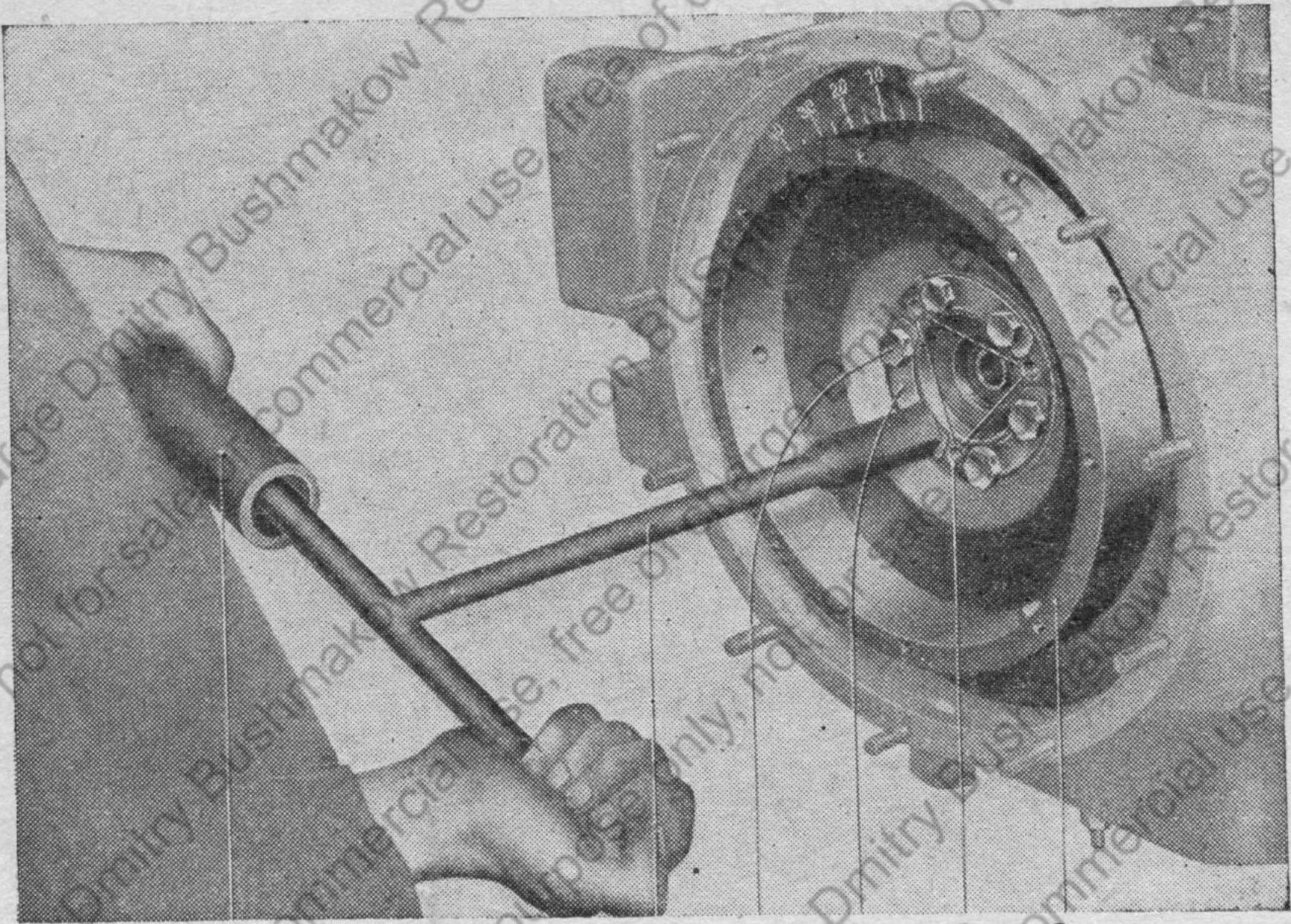

6 5 4 3 2 1

**Bild 25 Schwungrad ausbauen**

10 11 12 13

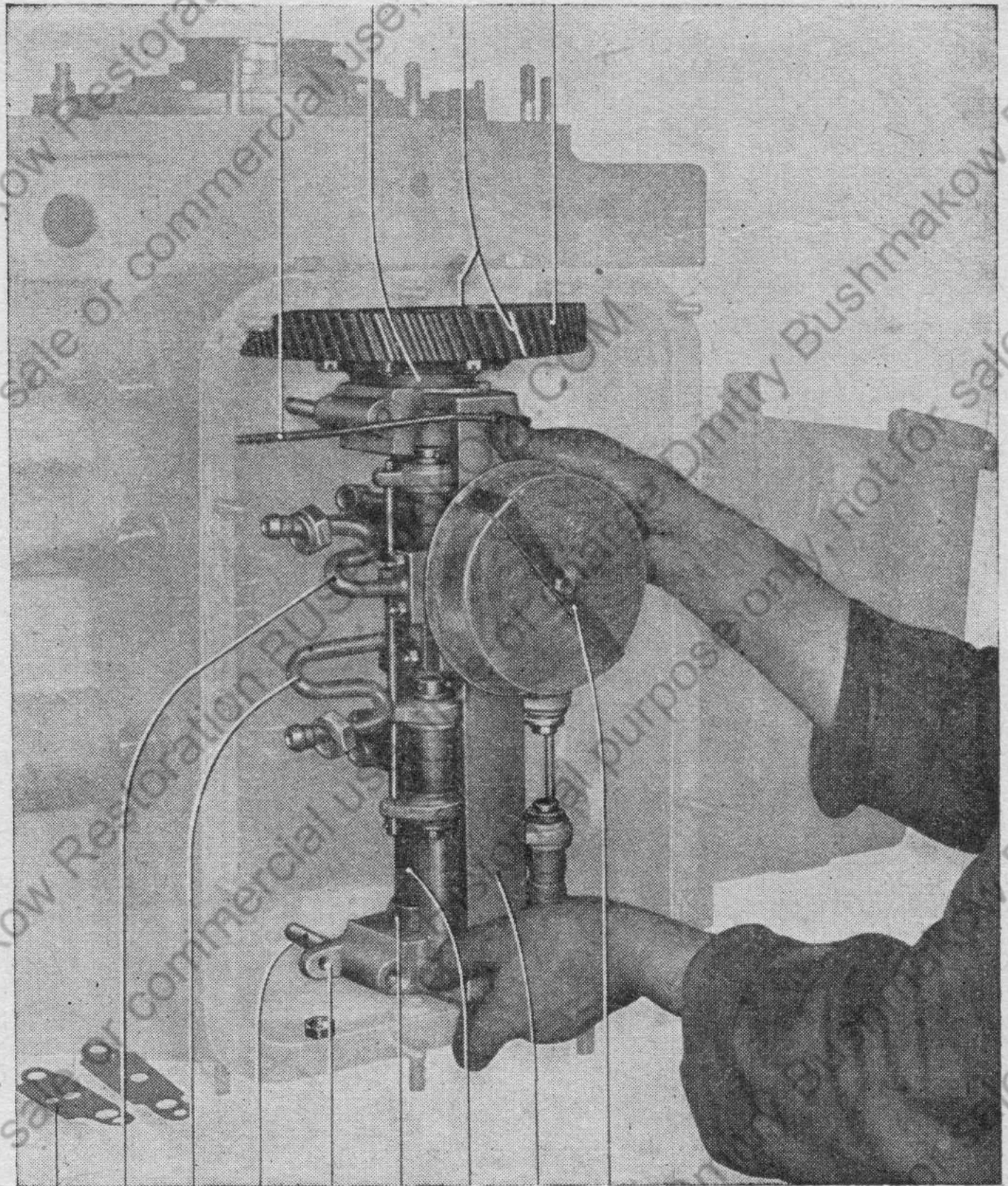

9 8 7 6 5 4 3 2 1



8 9 10 11

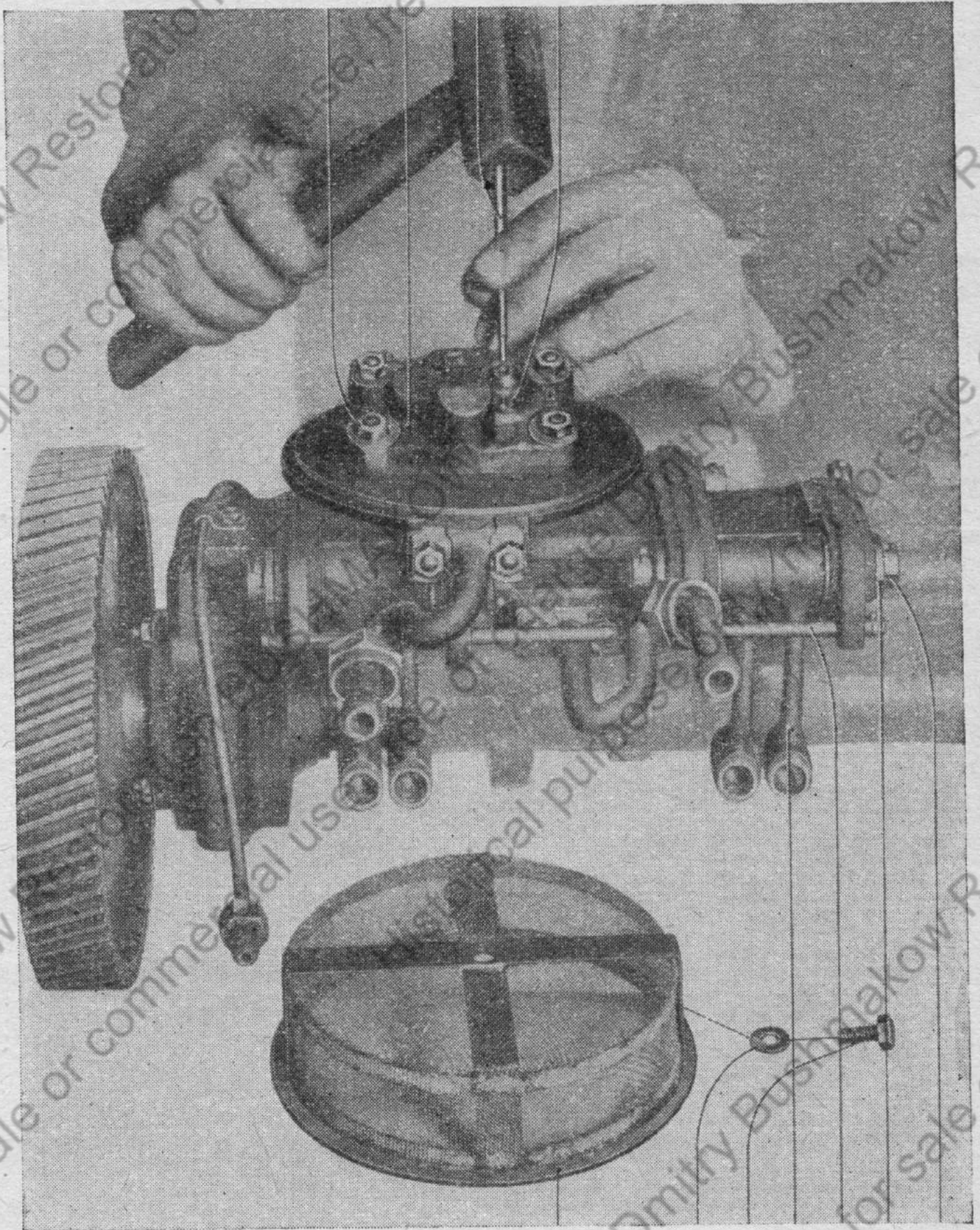

7 6 5 4 3 2 1

Bild 28 Ölpumpe ausbauen



7 8 9 10 11 12

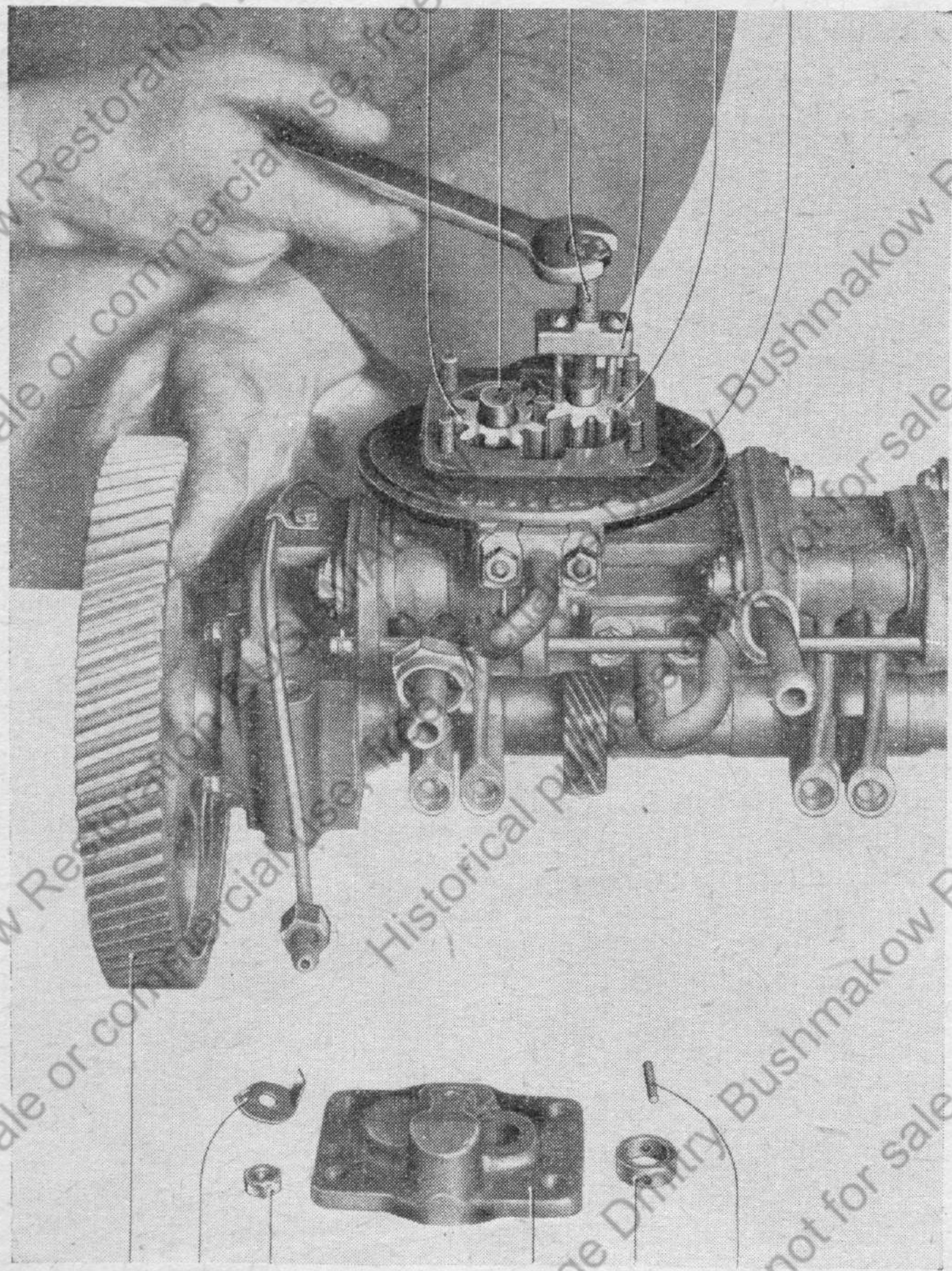

6 5 4 3 2 1



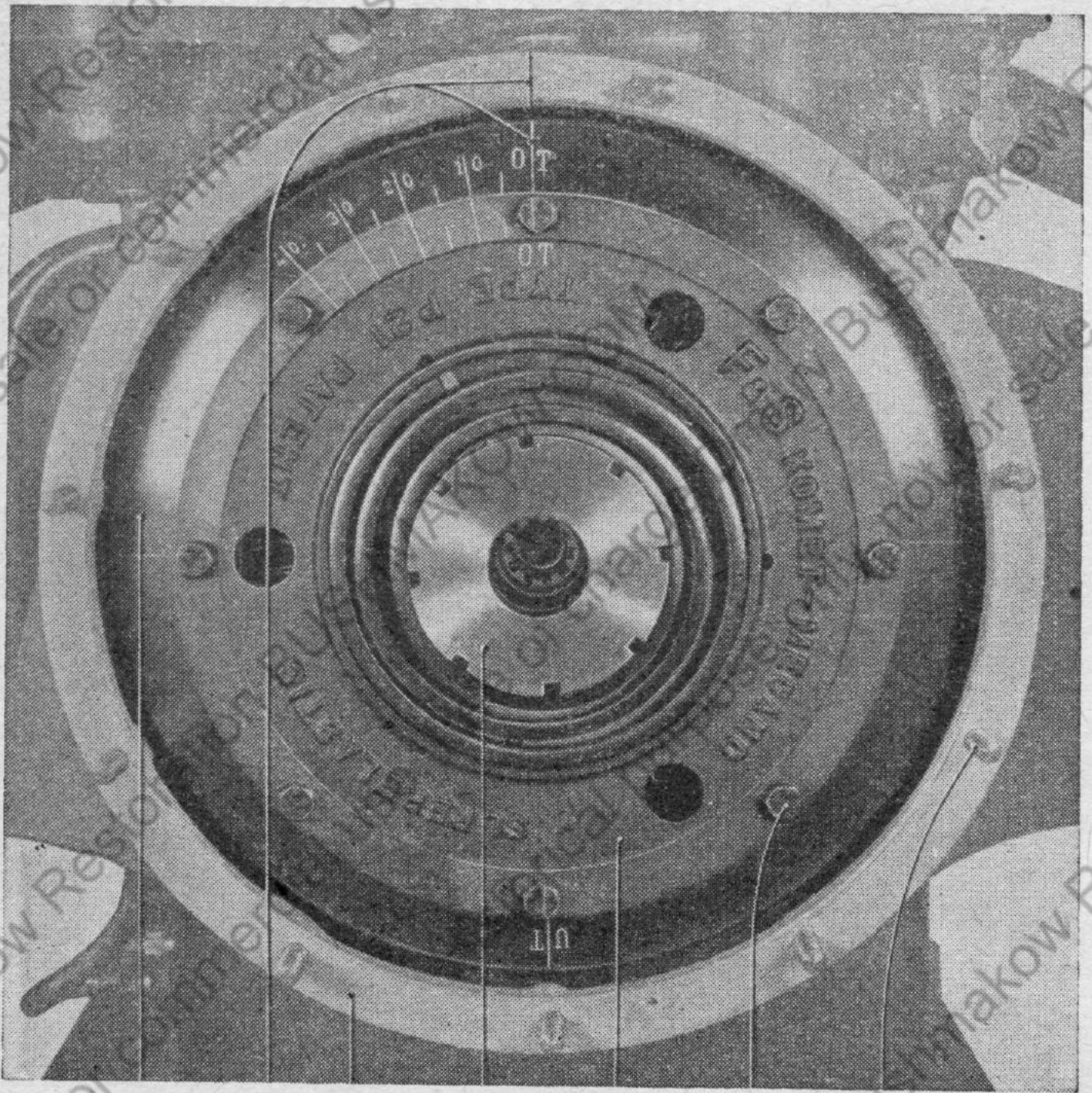

7 6 5 4 3 2 1

**Bild 31 Kupplung**

1 Stiftschraube für Getriebeboch



Bild 32 **Kupplung ausbauen**

1 Anpreßplatte

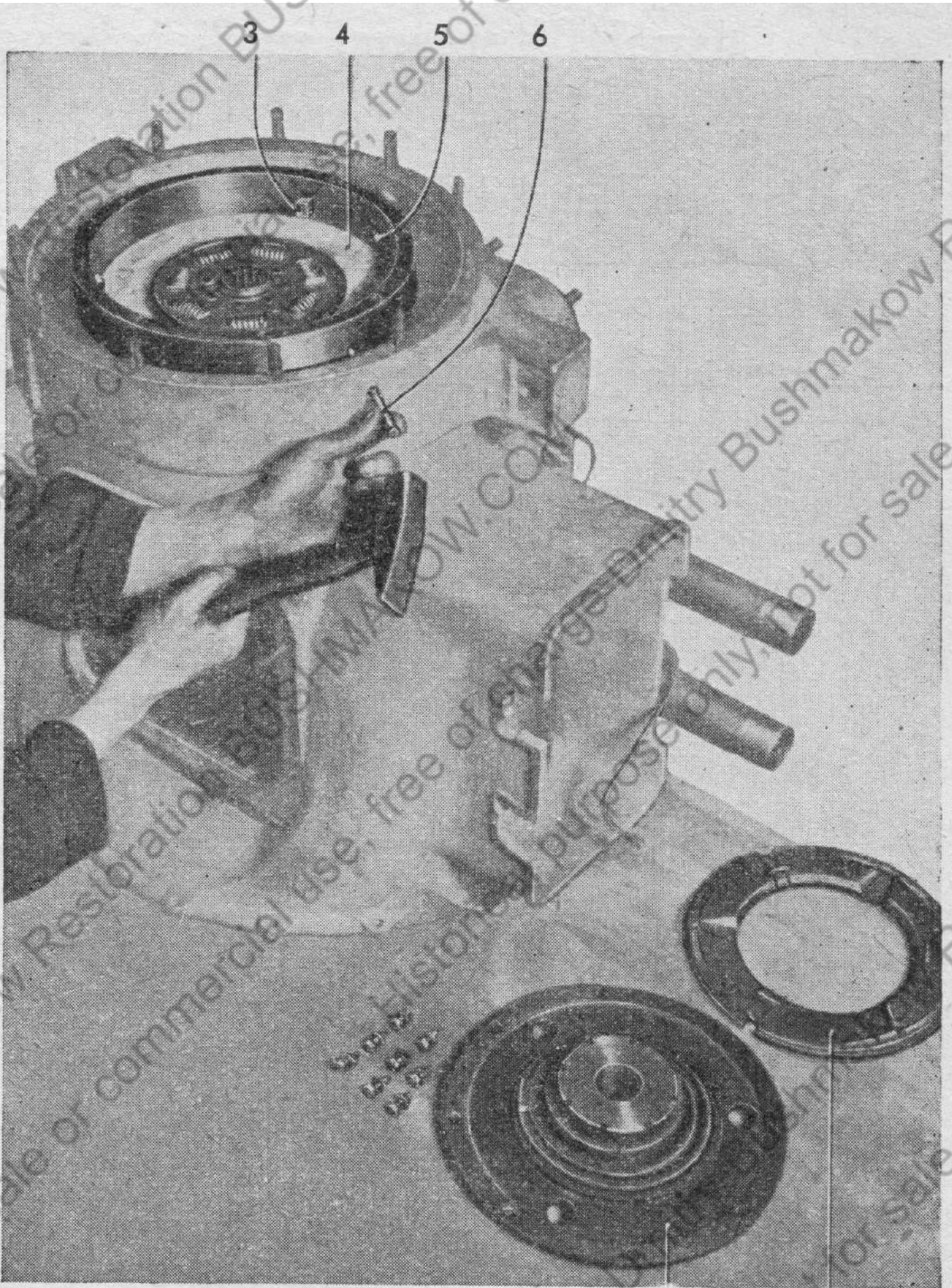
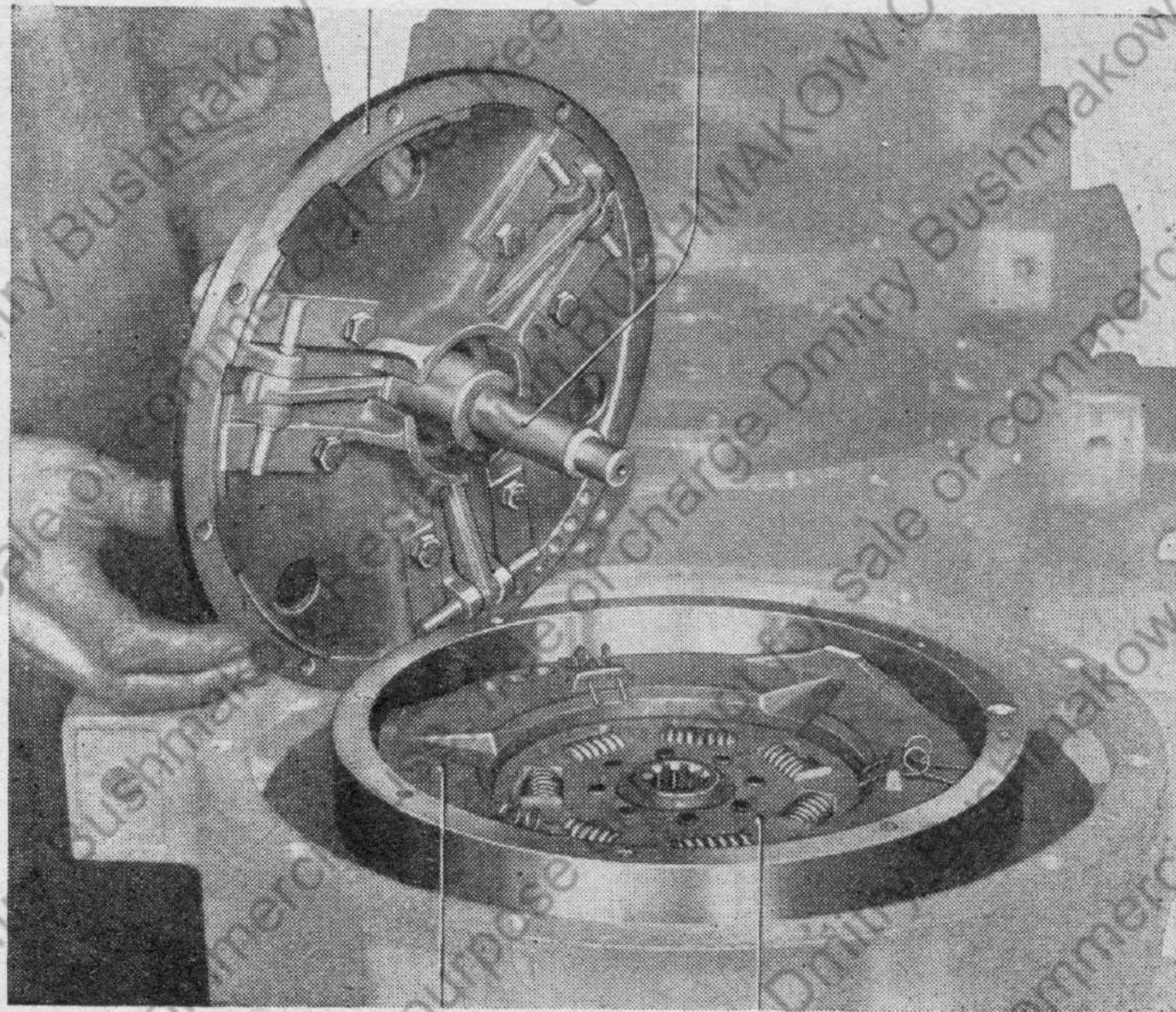

**Bild 33 Kupplung einbauen**

- 1 Mitnehmerscheibe
- 2 Antriebsplatte

(34/3) abschrauben

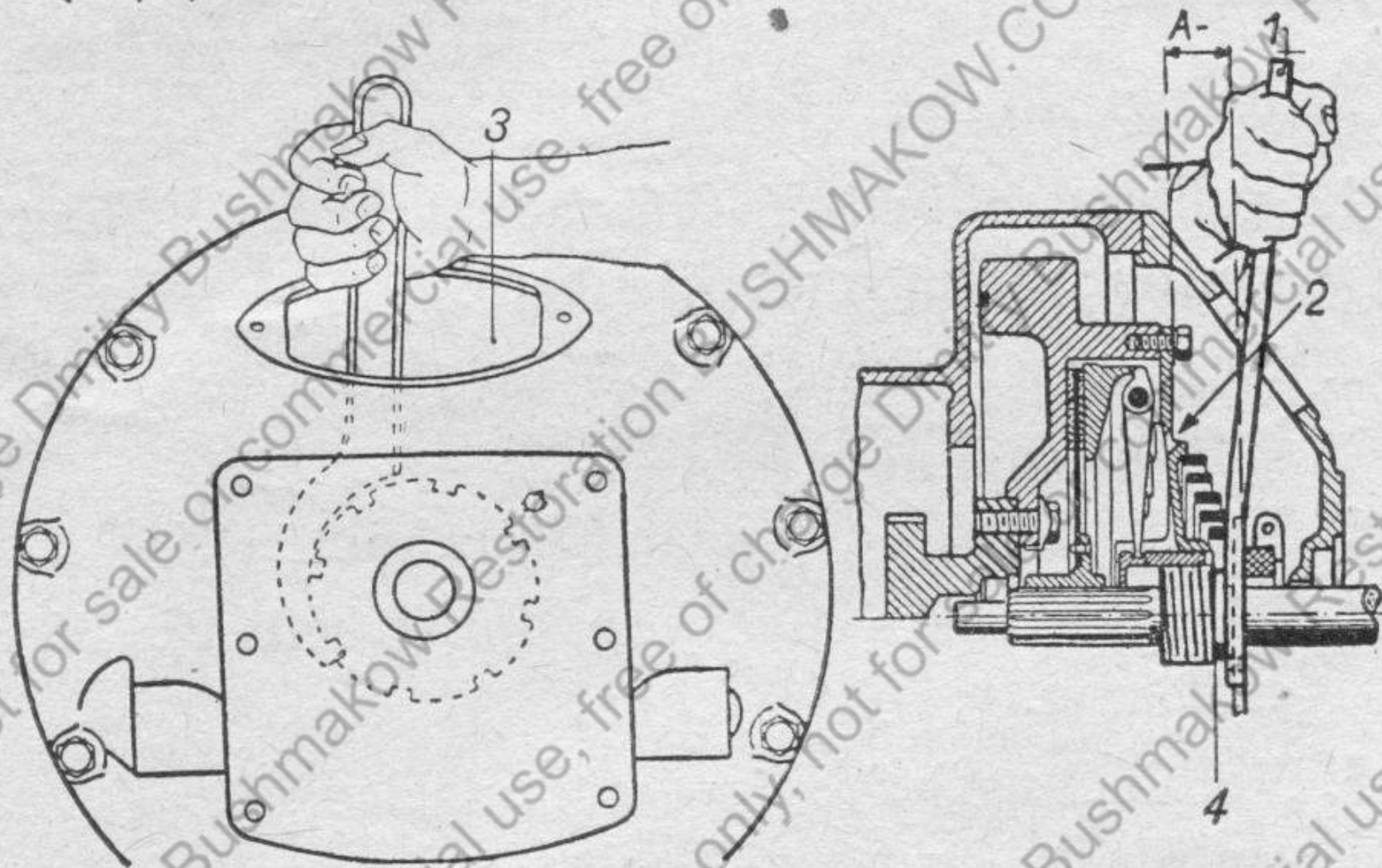

**Bild 34 Kupplung nachstellen**

A = 33 mm (Einstellänge)

1 Hakenschlüssel  
2 Ölloch

3 Handloch  
4 Stellmutter

7 8 9

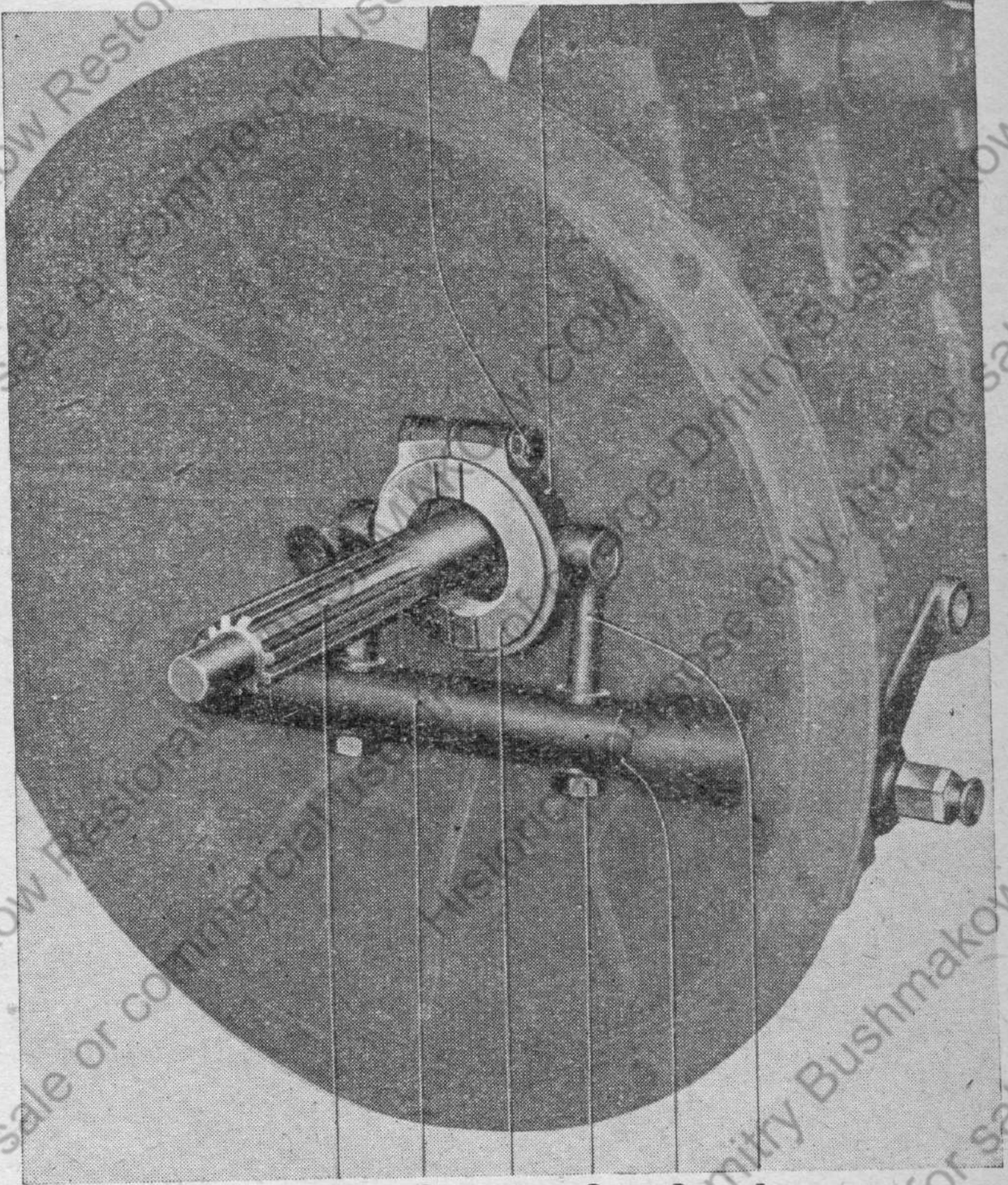

6 5 4 3 2 1

8

9

10

11

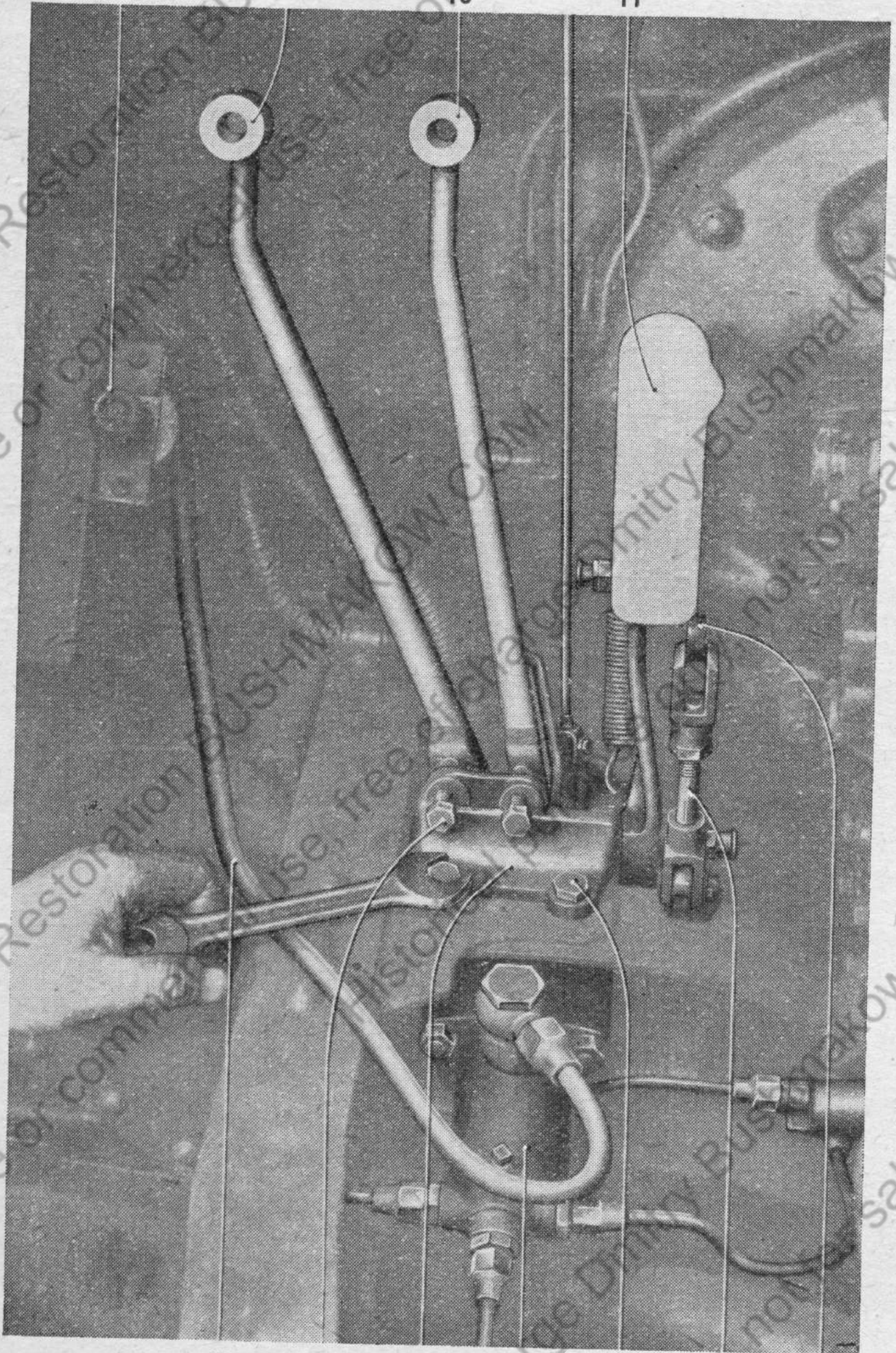

7

6

5

4

3

2

1





Bild 37

## Kupplungsstück zur Lichtanlaßmaschine ausbauen

1 Kurbelgehäuse  
2 Lüfter (Windrad)

4 Kupplungsstück zur Licht-  
anlaßmaschine





Bild 39 Lüfter (Windrad) abziehen



10 11 12 13 14 15 16 17 18

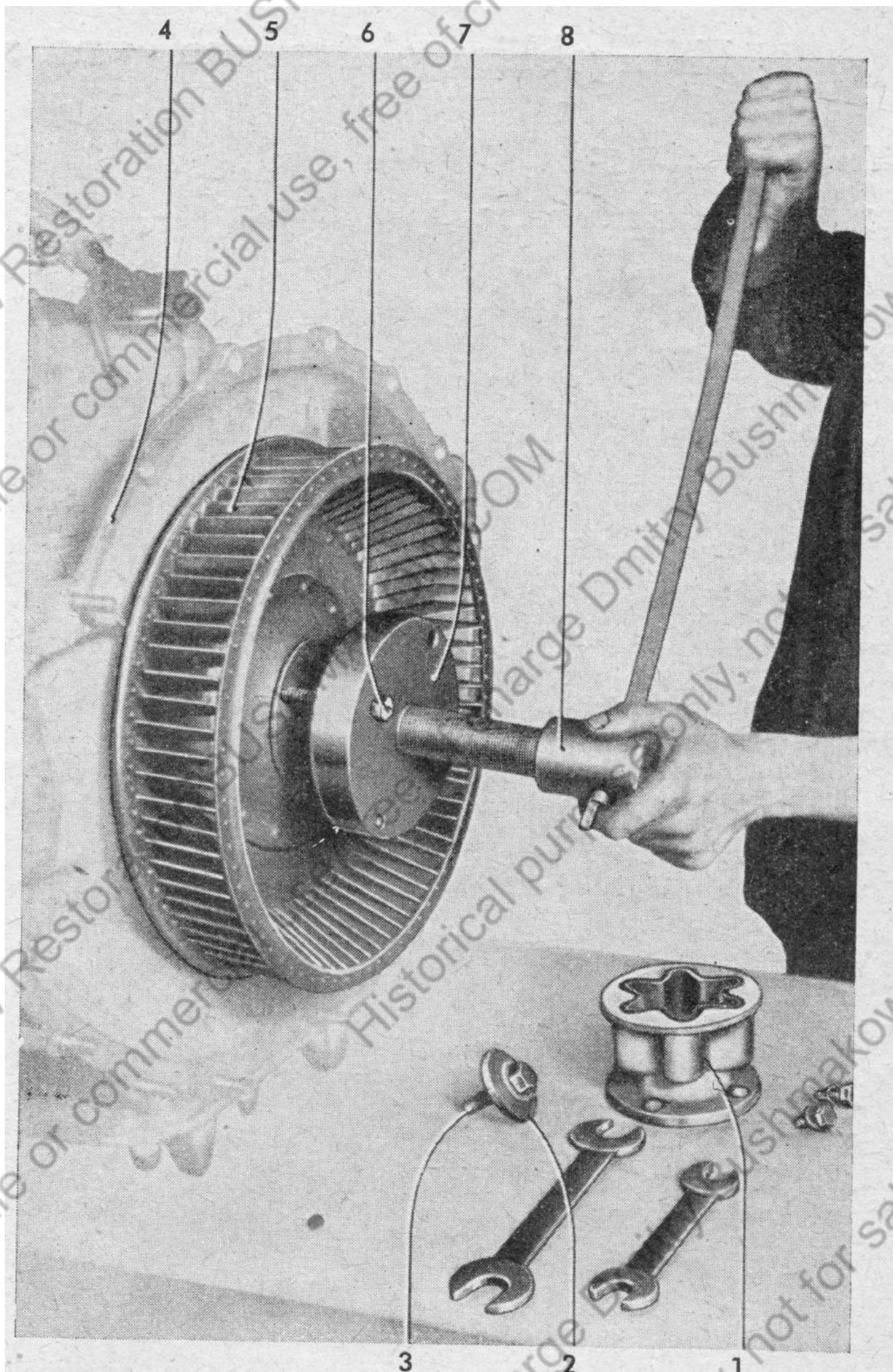
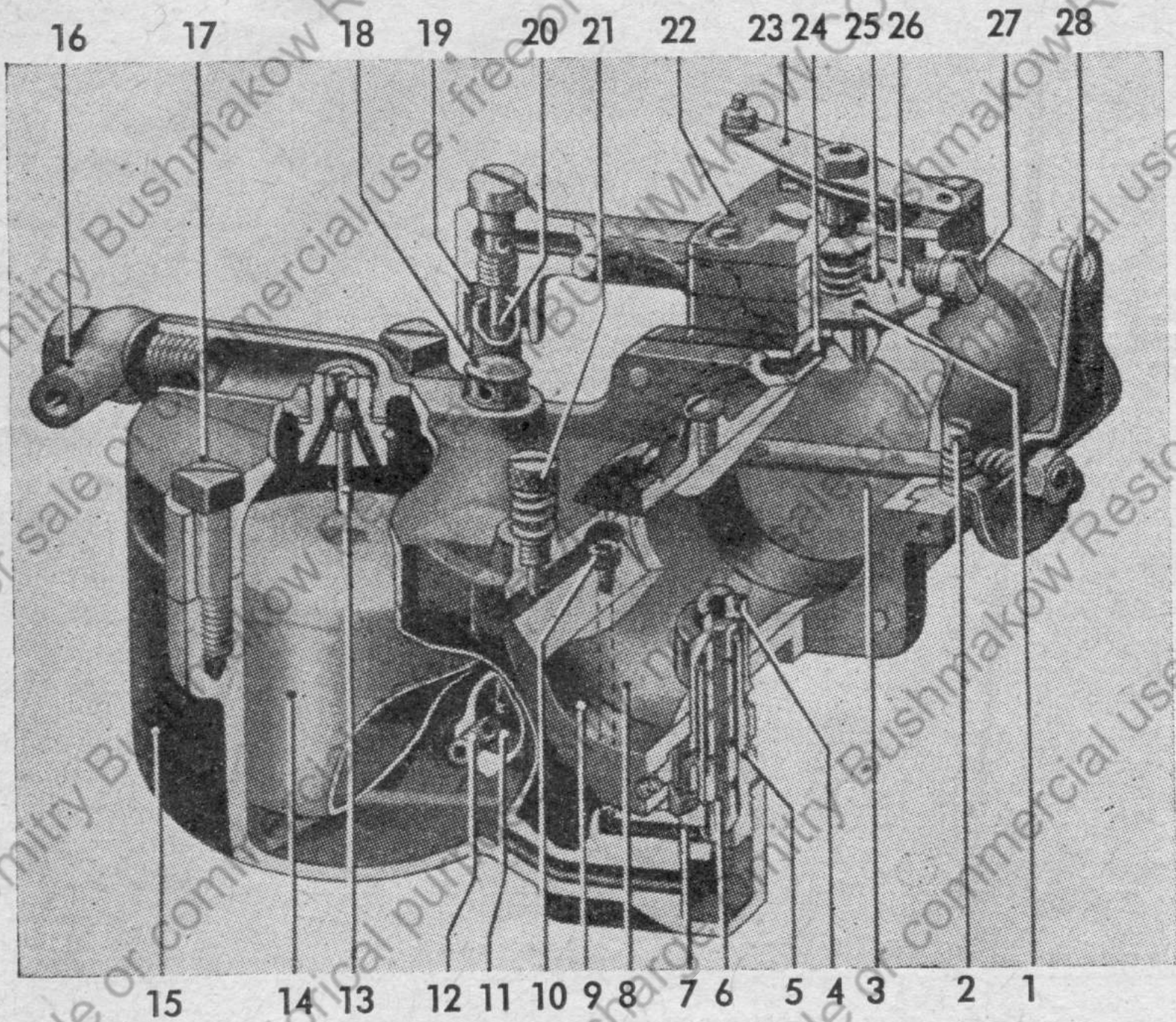
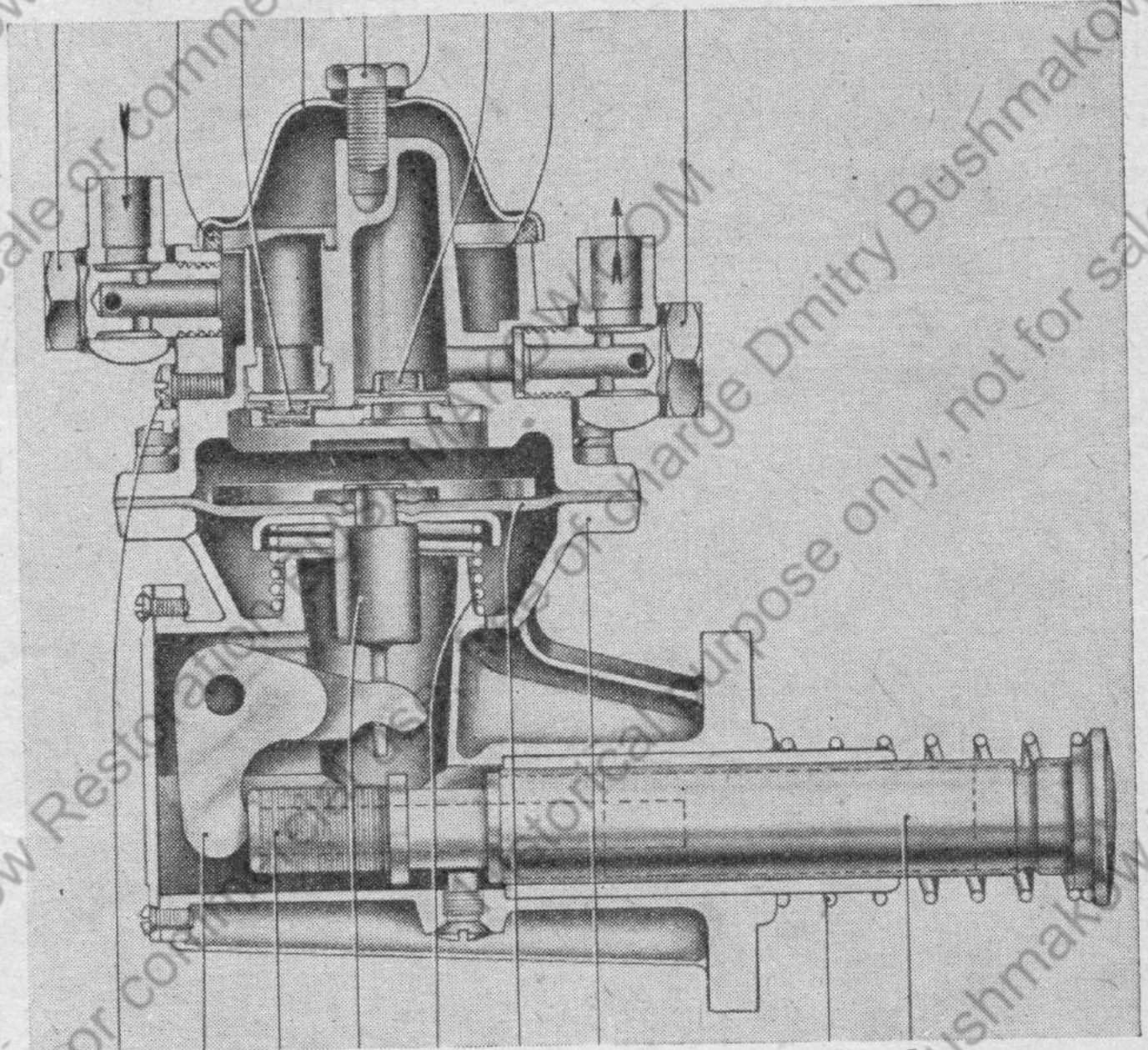

9 8 7 6 5 4 3 2 1

**Bild 41 Kraftstoffpumpe**

0 W... 1-2

15 Dichtung zur

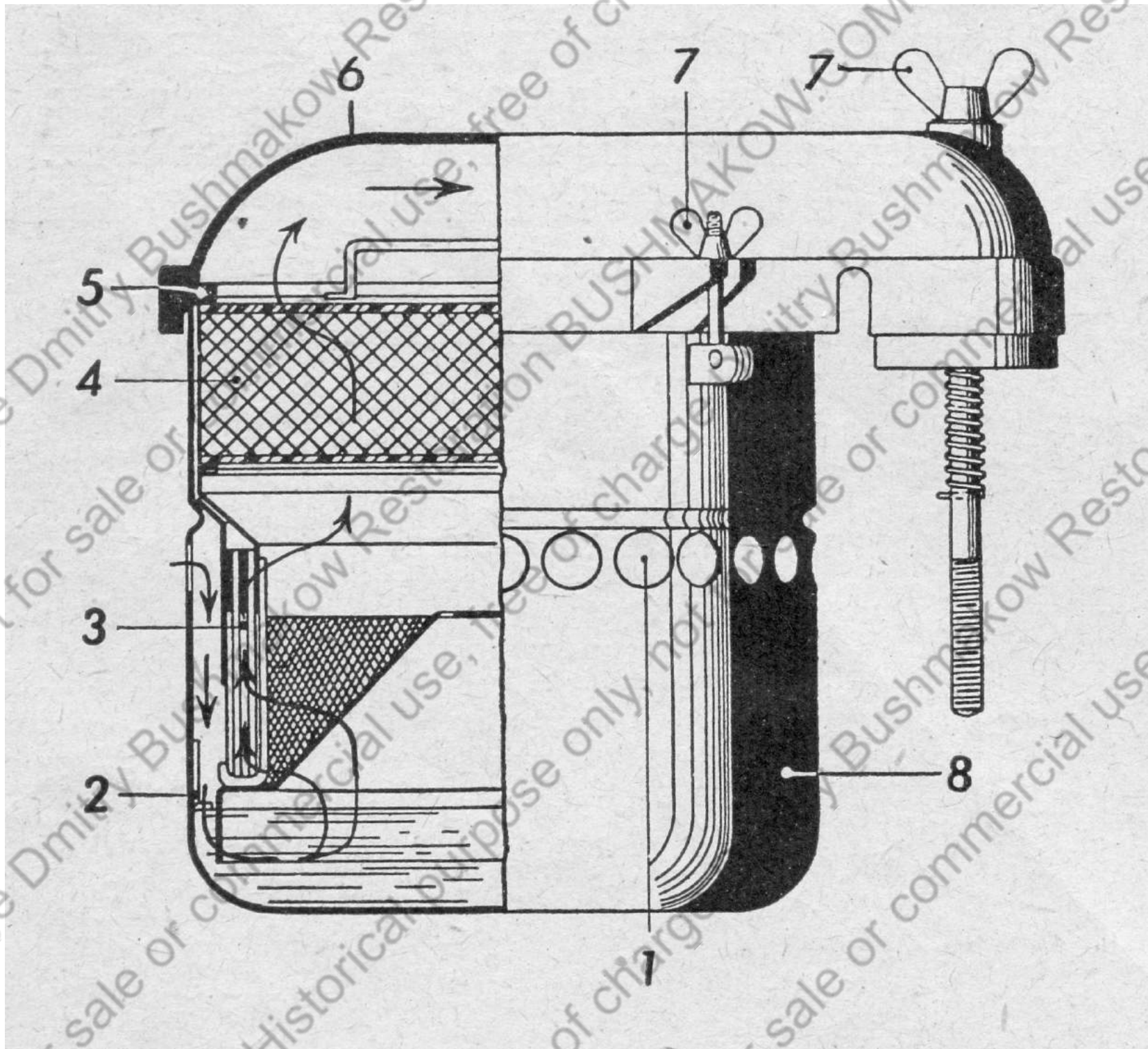



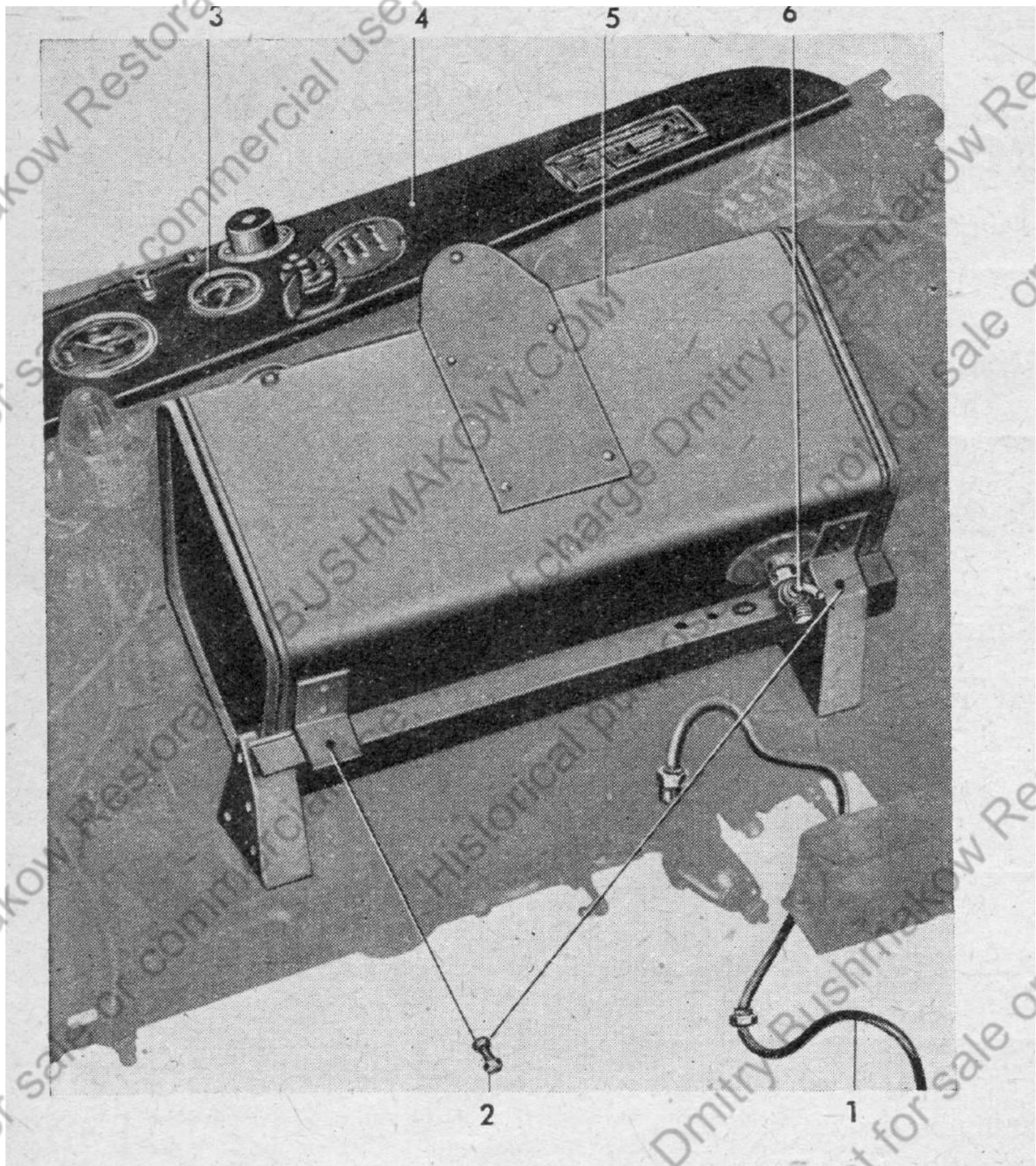



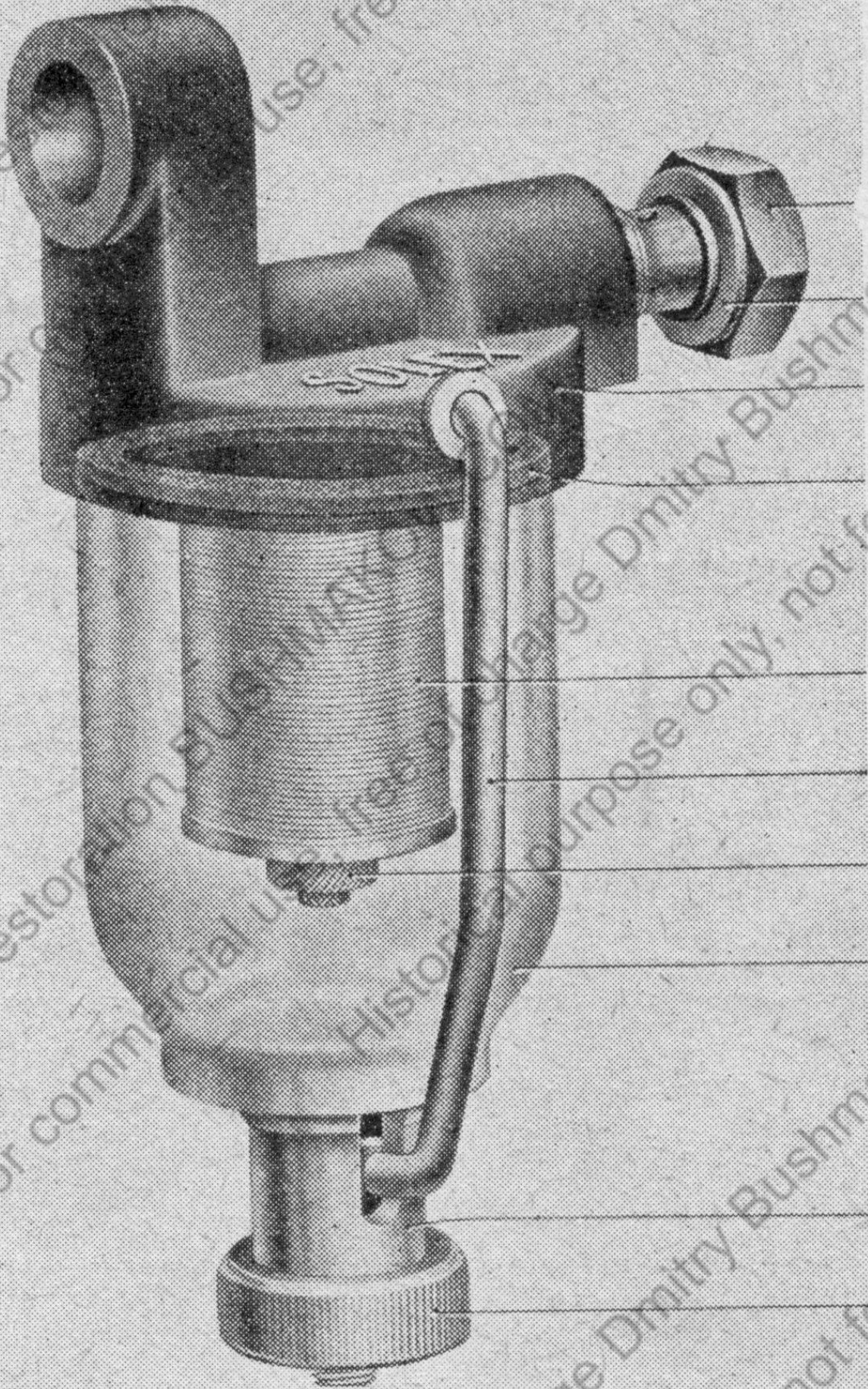

10

9

8

7

6

5

4

3

2

1

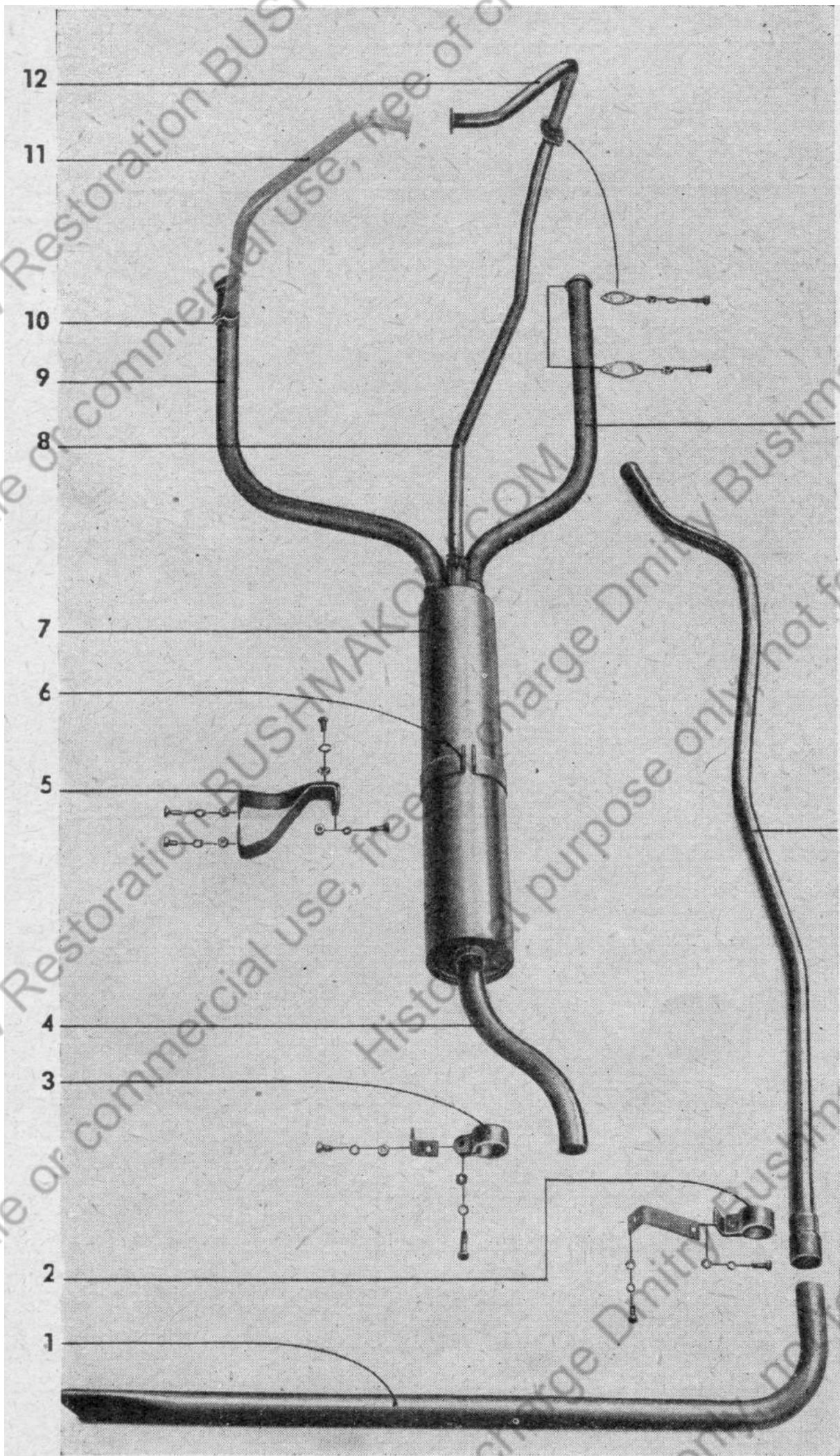



Bild 47 Wechselgetriebe (Ansicht von rechts)

1 Getriebegehäuse

6 Schalthebel für Wechselgetriebe

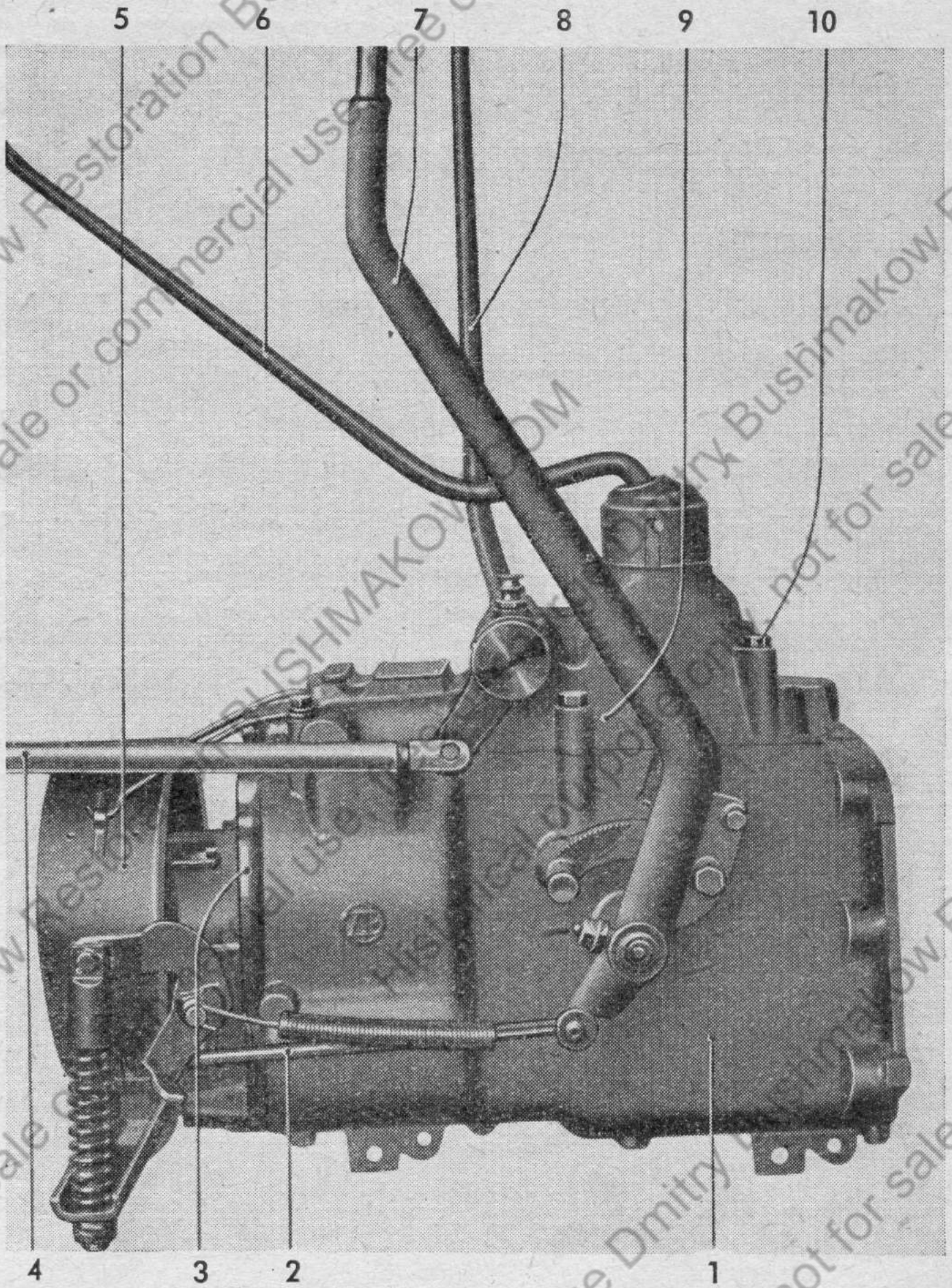
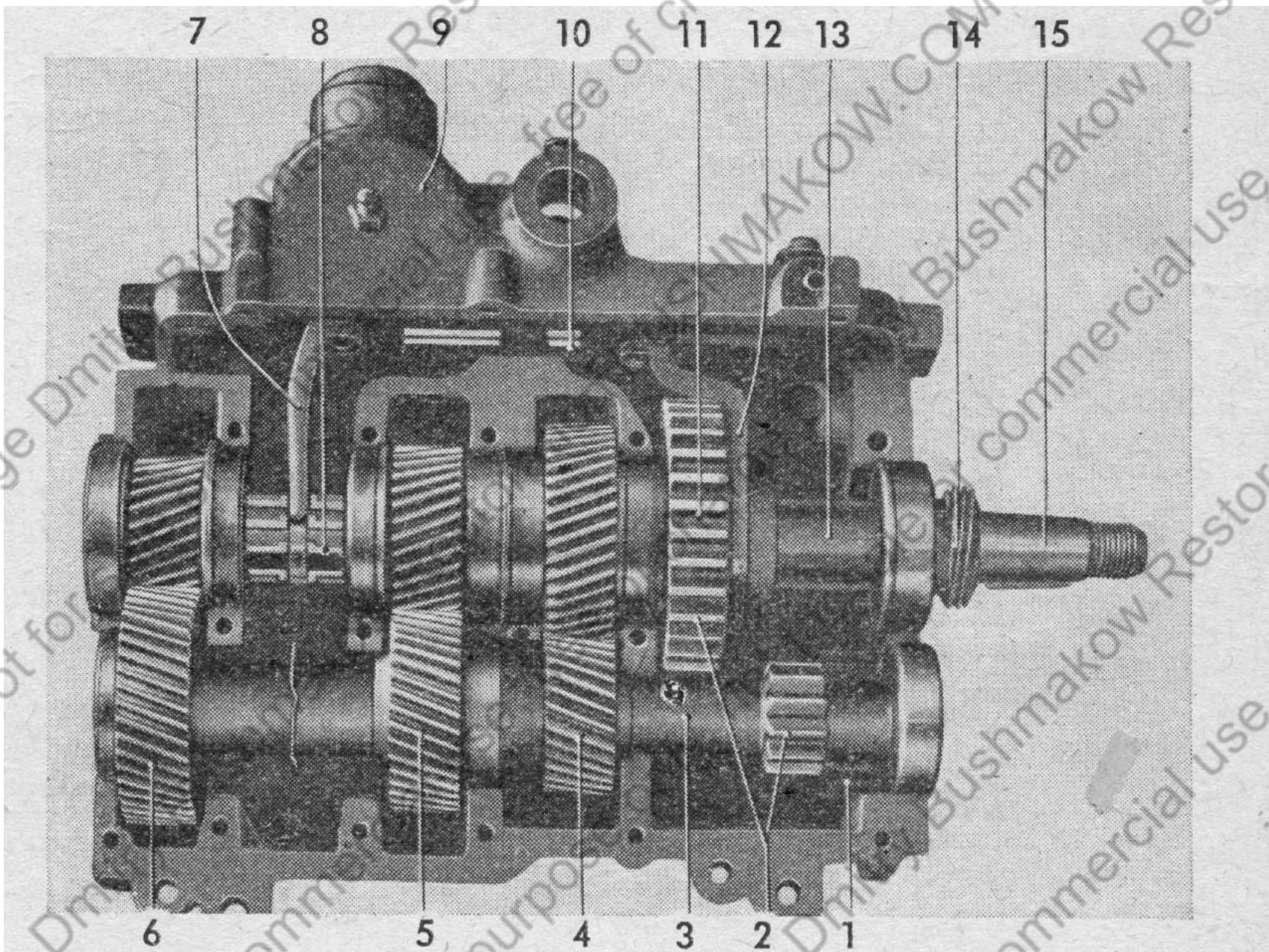

**Bild 48 Wechselgetriebe**  
(rechte Gehäusenhälfte in Fahrtrichtung gesehen)

1 Rückwärtsgang      7 Schaltgabel      12 Schaltgabel

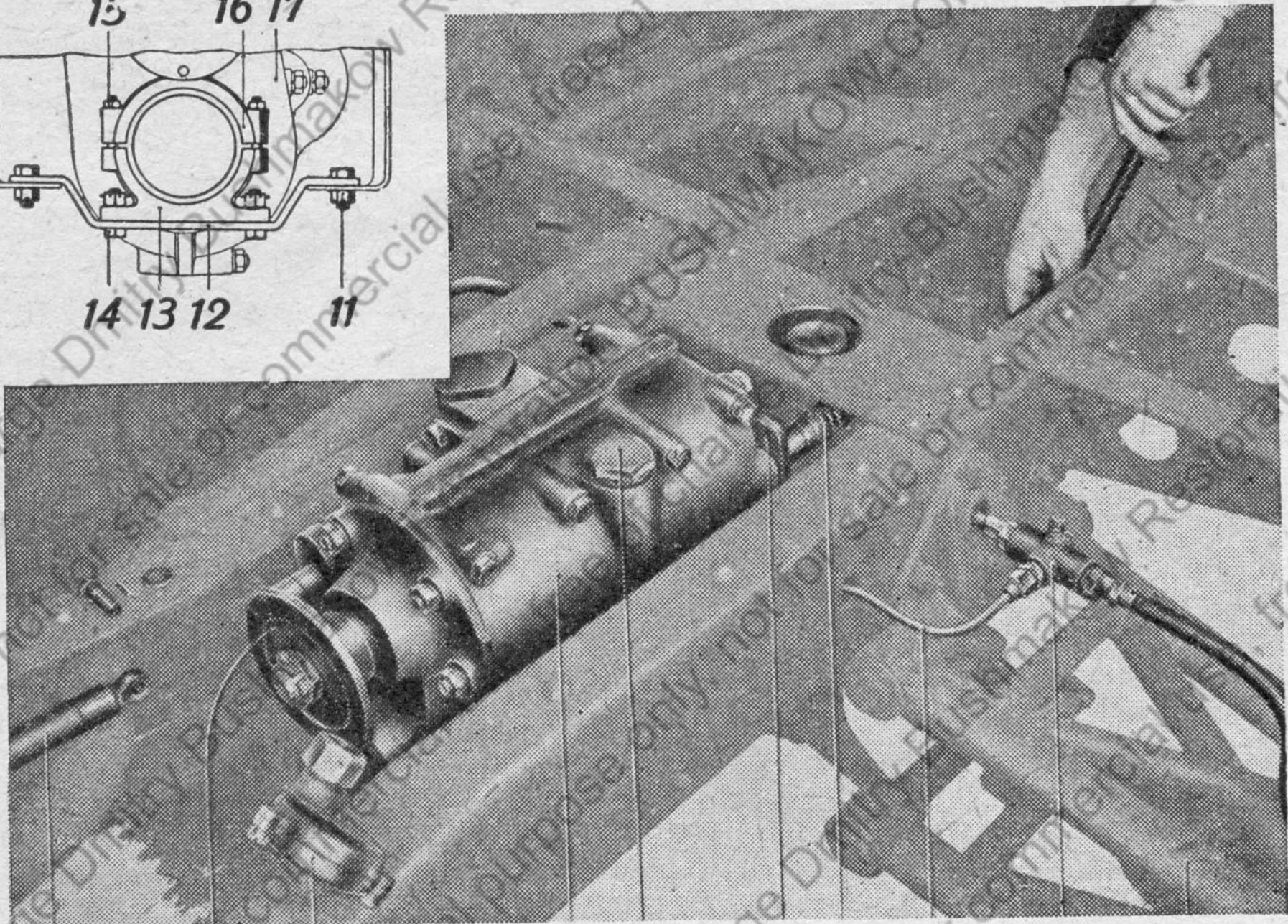
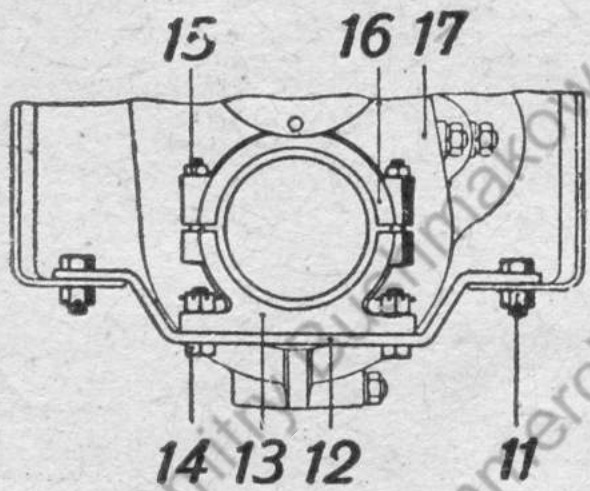

10 9 8 7 6 5 4 3 2 1

Bild 10 Zusatzgetriebe aushauen

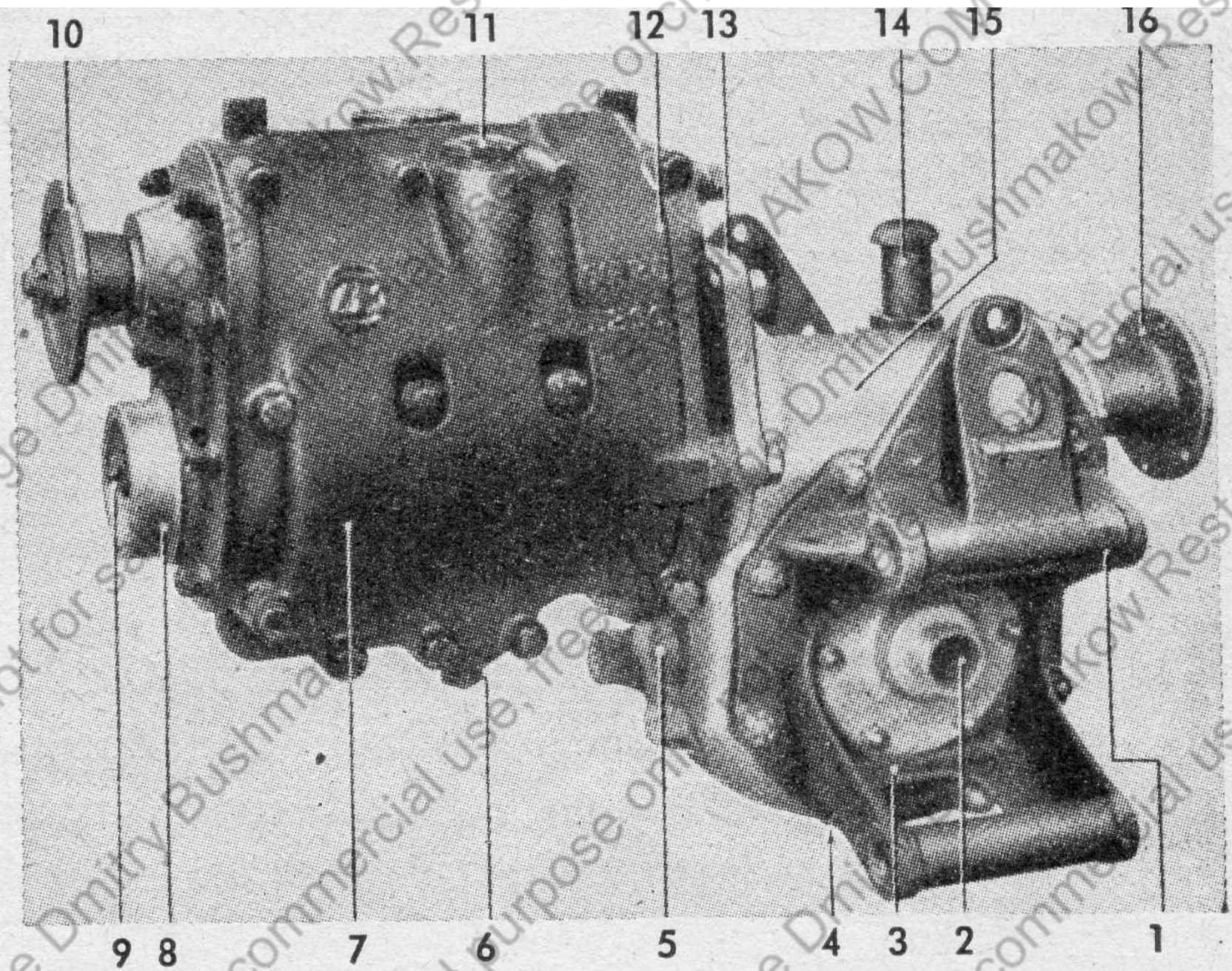

**Bild 50. Zusatzgetriebe mit Mittelachsenantrieb**

1 Lager für Querlenker

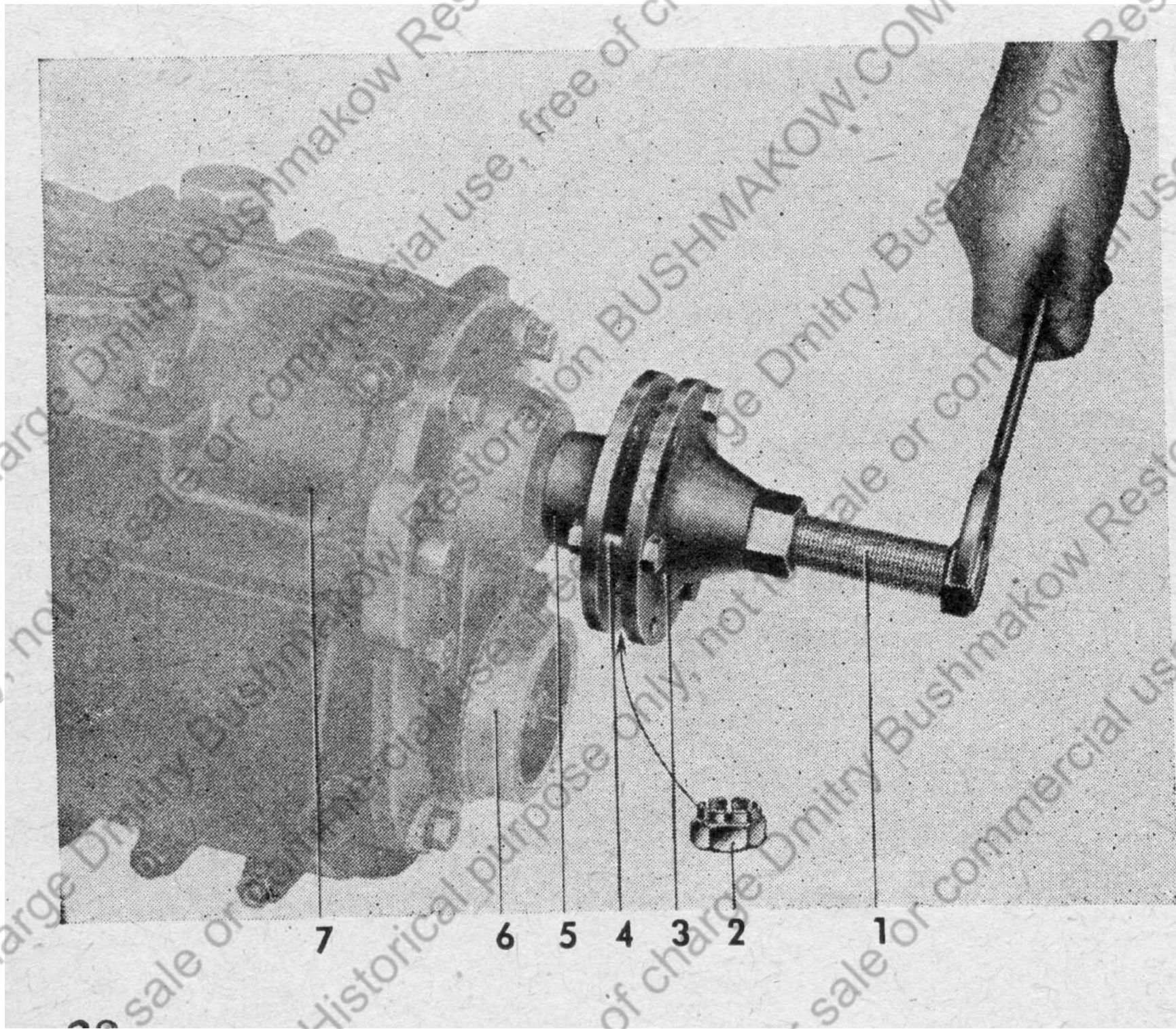



Bild 52 Zusatzgetriebe





Bild 53 Vorderachse

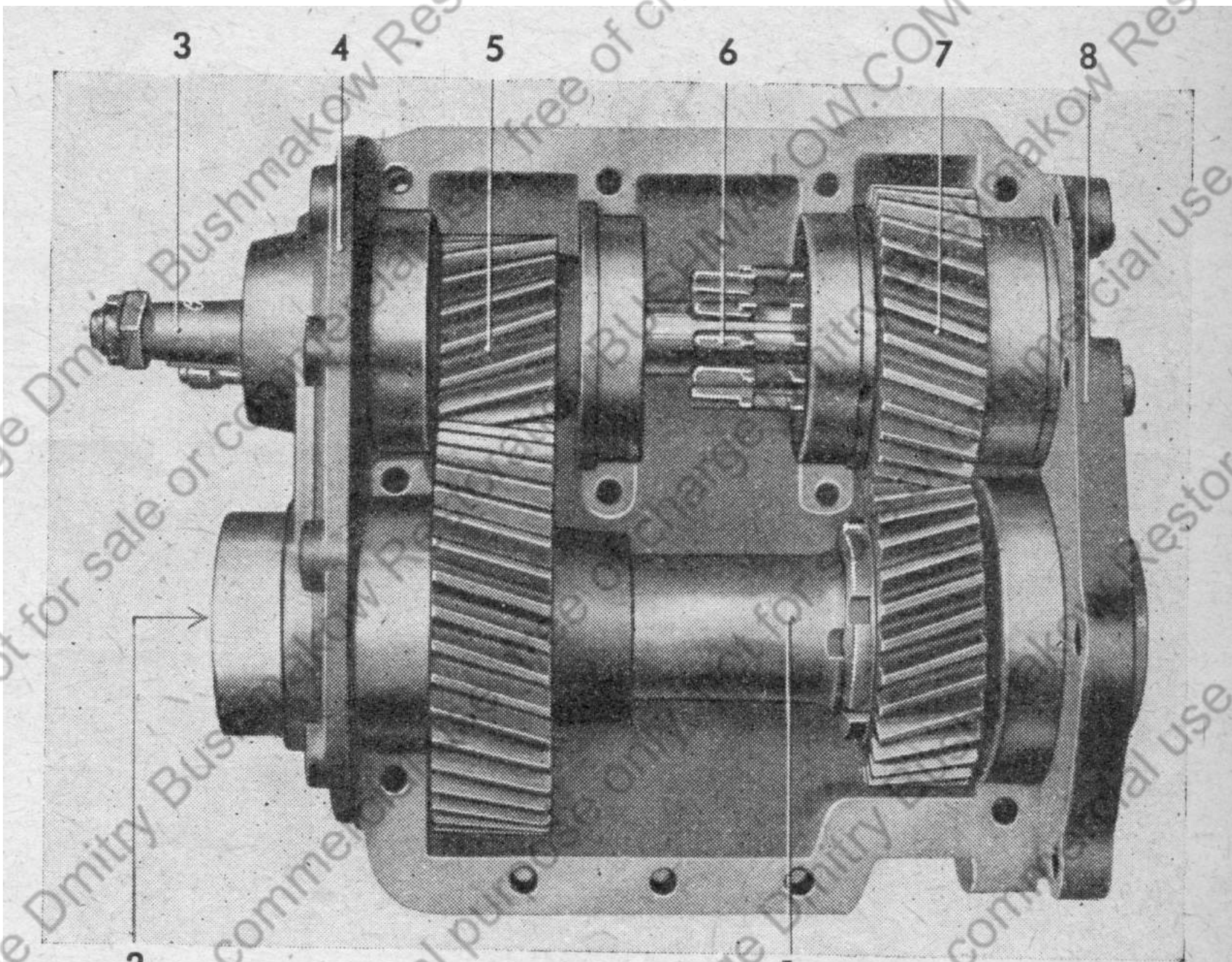

Bild 54 Achsschenkel ausbauen

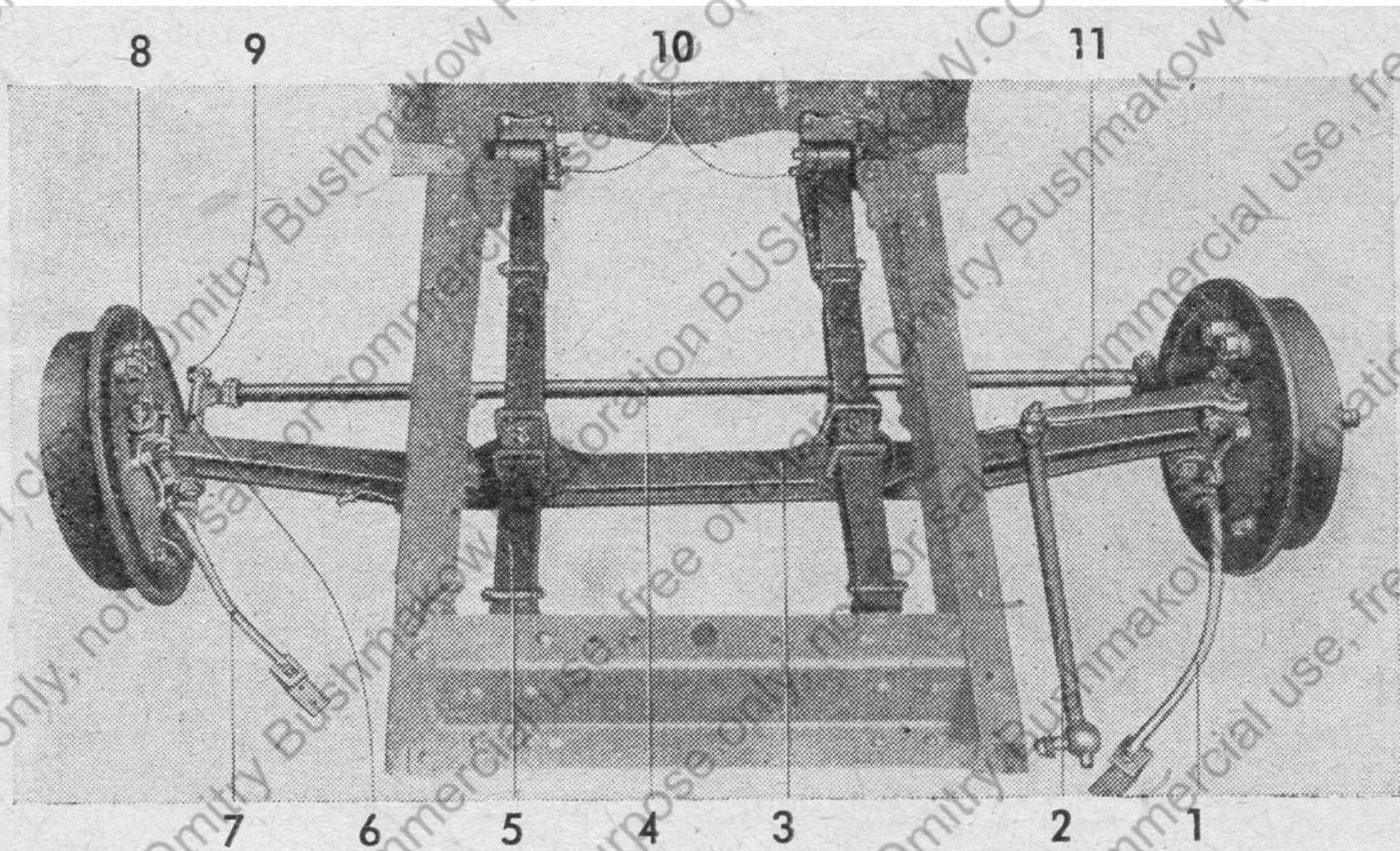

Bild 55 **Spurstange verstellen**

1 Spurstangenhebel

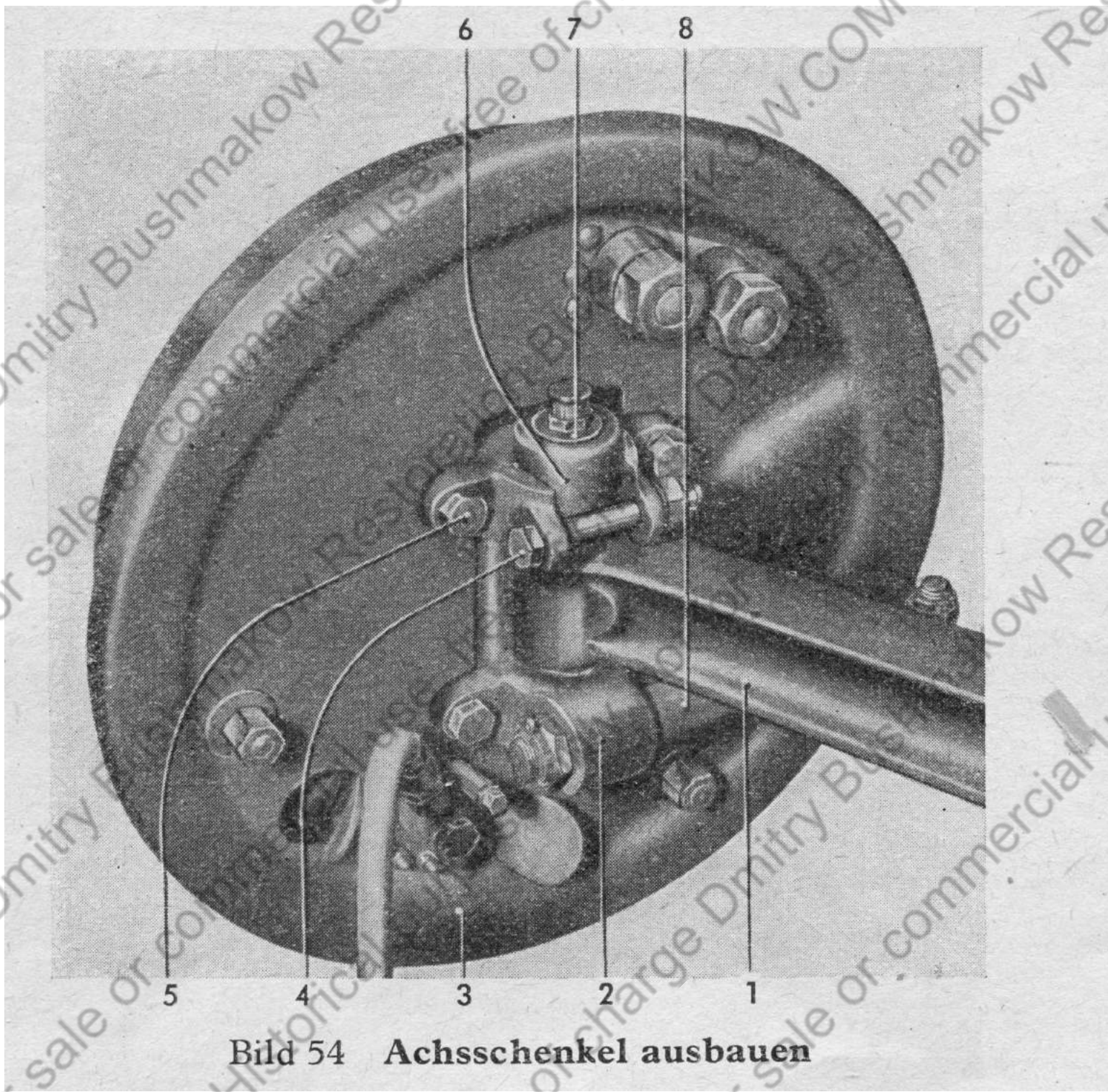
6 Vorderachse

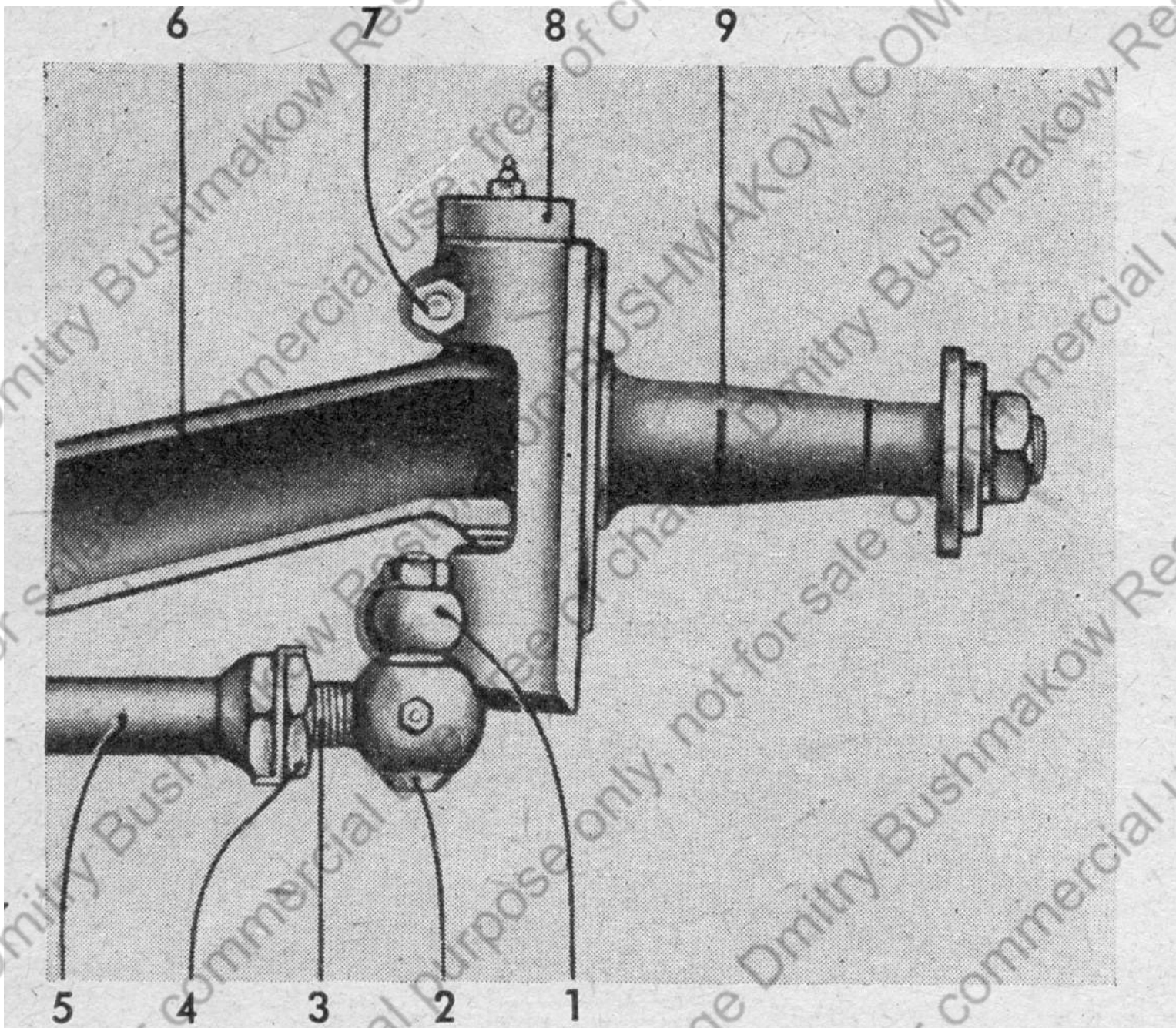
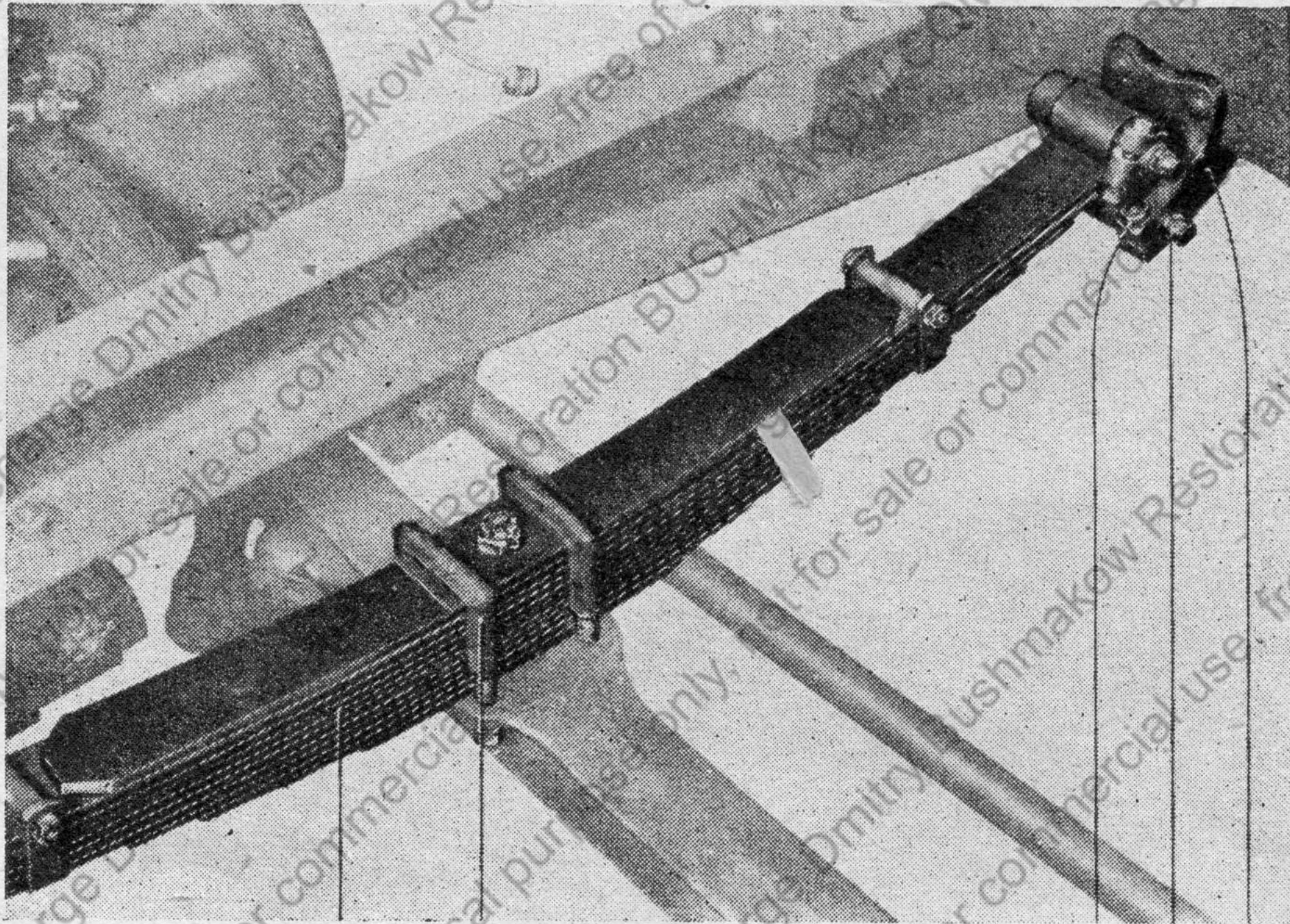

5

4

3

2

1

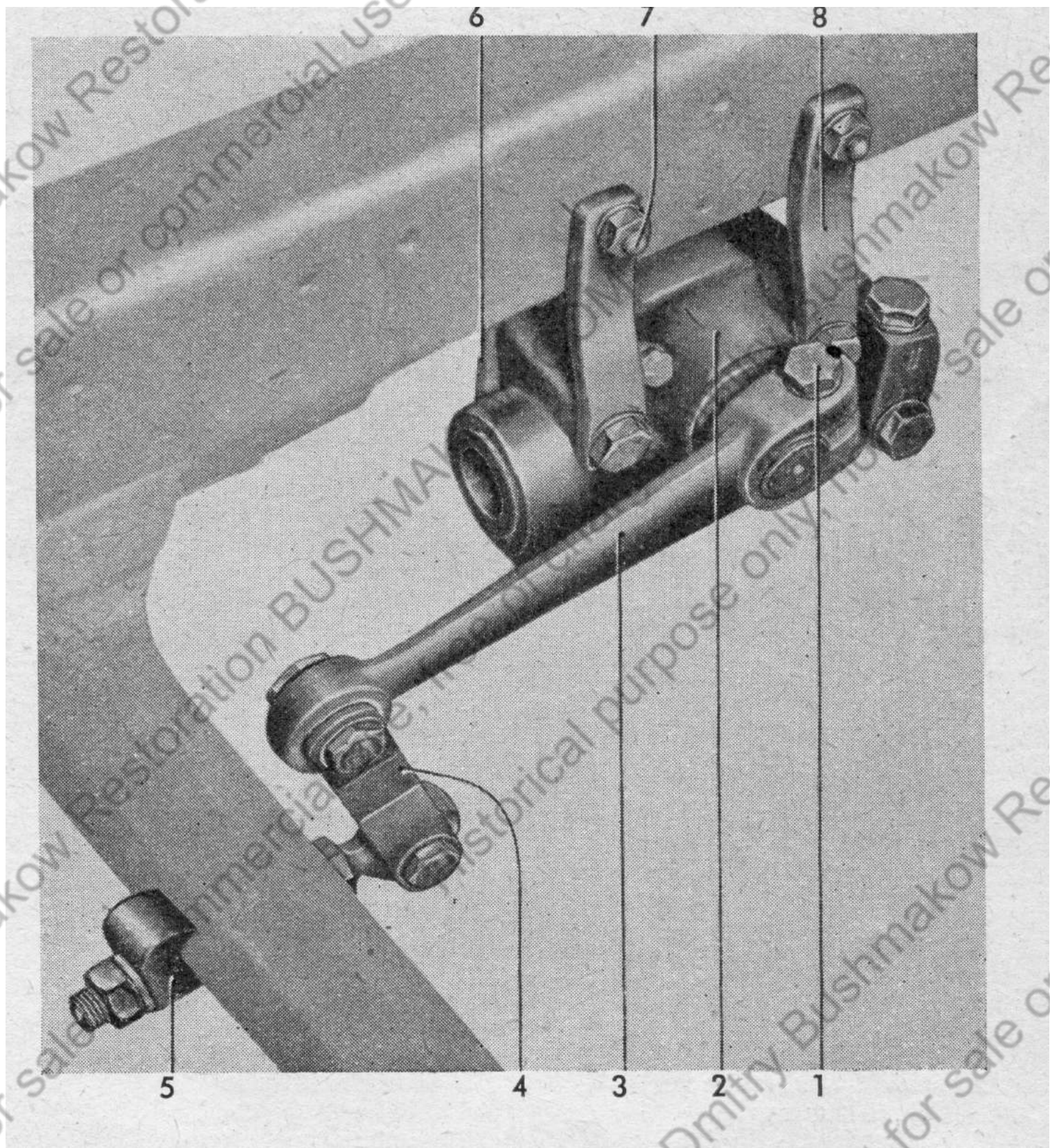

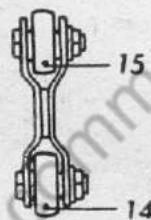
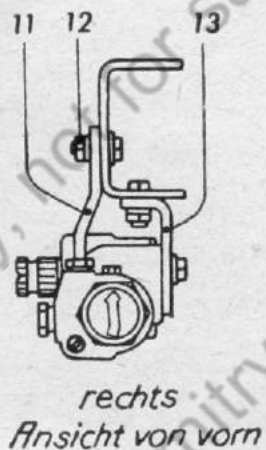
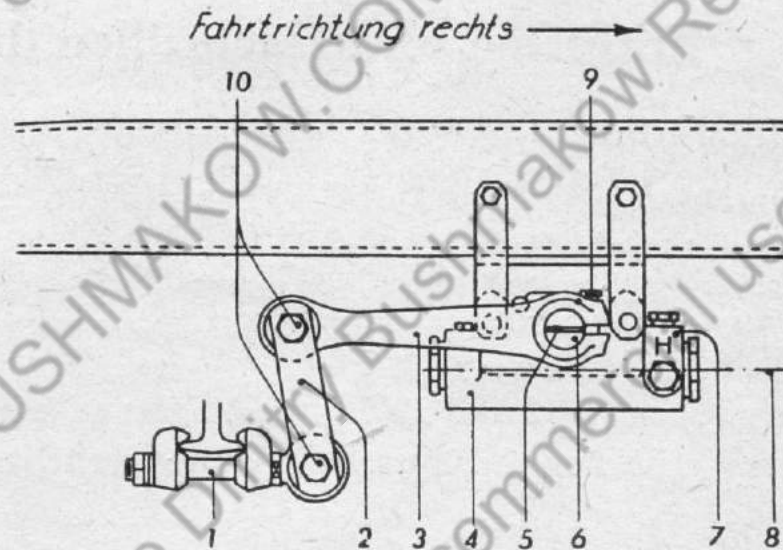
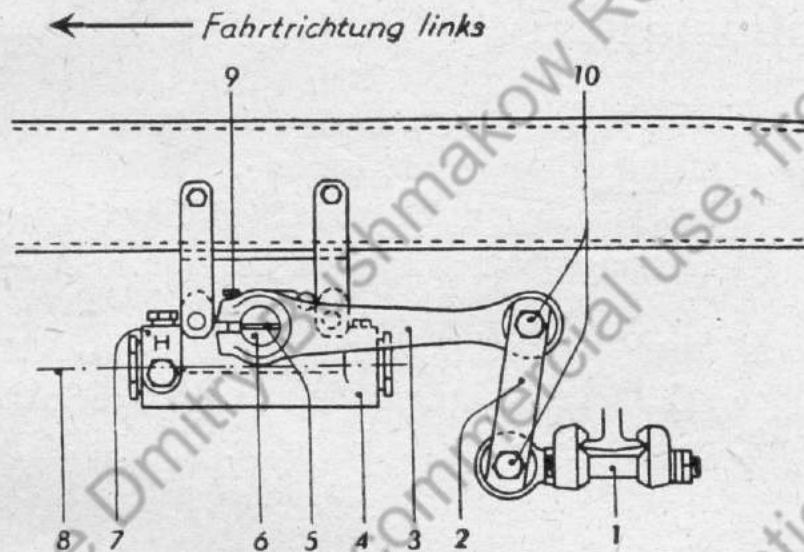

### Arbeitsumfang:

Beim Einbau eines neuen Stoßdämpfers ist darauf zu achten, daß die Hochdruckseite — eingegossenes H (rot) — stets in **Fahrtrichtung nach vorn** (siehe Bild 58) liegt, da sonst die Wirkungsweise des Stoßdämpfers in Frage gestellt ist.

Bild 58 Vorderer Stoßdämpfer

- |                    |                            |                     |
|--------------------|----------------------------|---------------------|
| 1 Achsklaue        | 6 Verzahnte Welle          | 11 Lasche           |
| 2 Gestänge         | 7 Hochdruckseite           | 12 Schraube         |
| 3 Schwinghebel     | 8 Mittellinie des Gehäuses | 13 Stoßdämpferbock  |
| 4 Niederdruckseite | 9 Klemmschraube            | 14 Achsklauenaue    |
| 5 Strichmarke      | 10 Schraube                | 15 Schwinghebelauge |



Bild 59 **Stoßdämpfer**







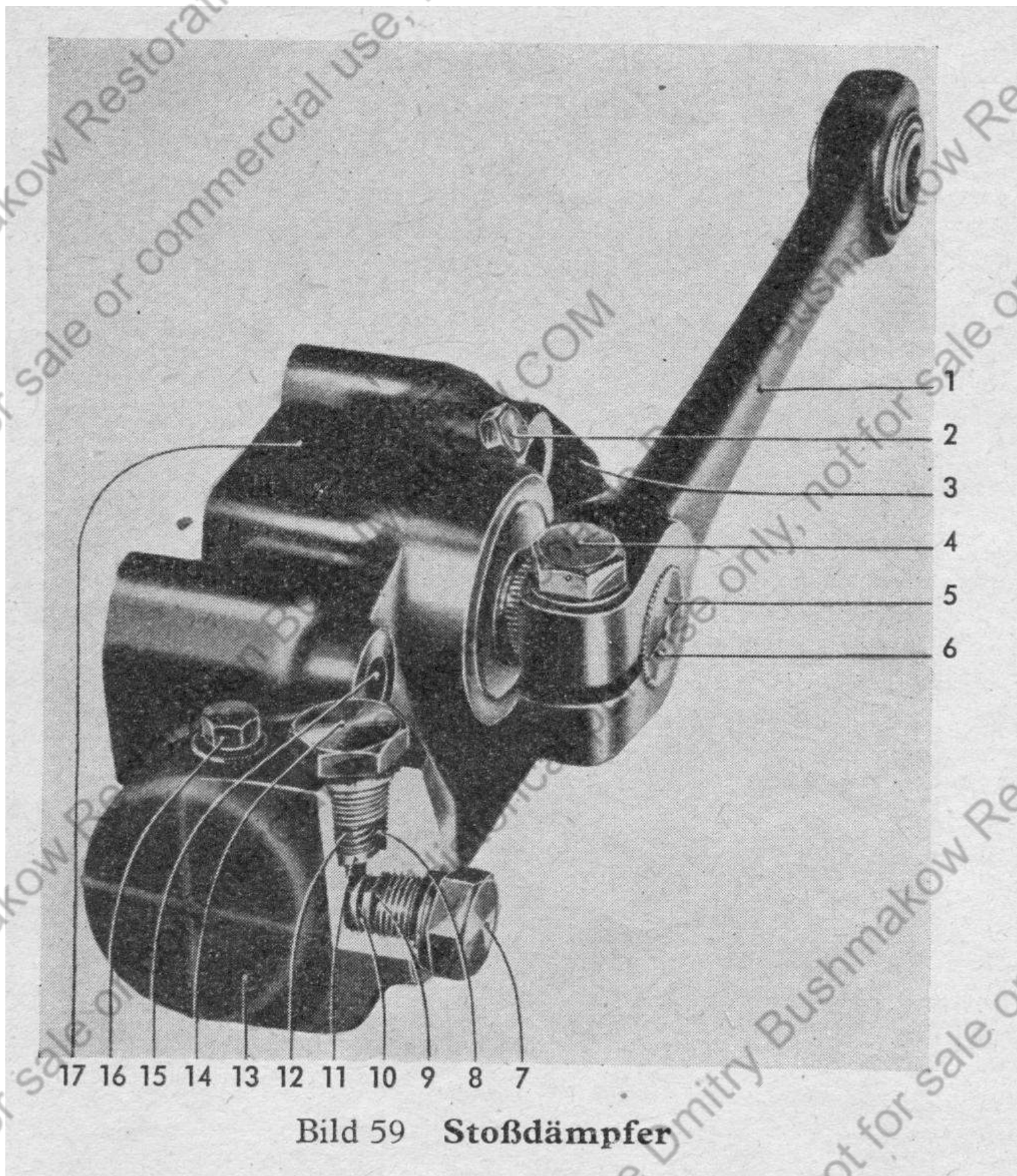
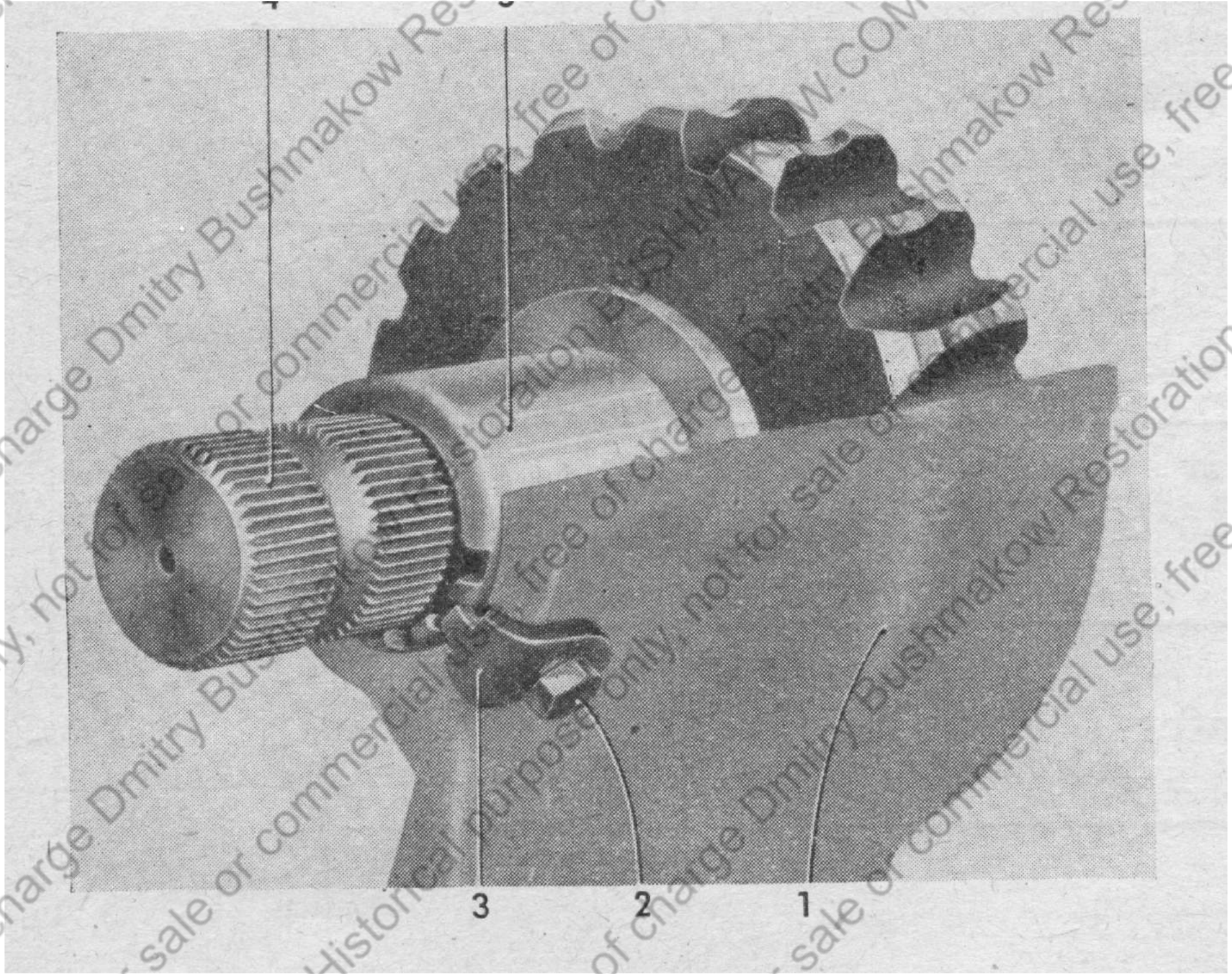
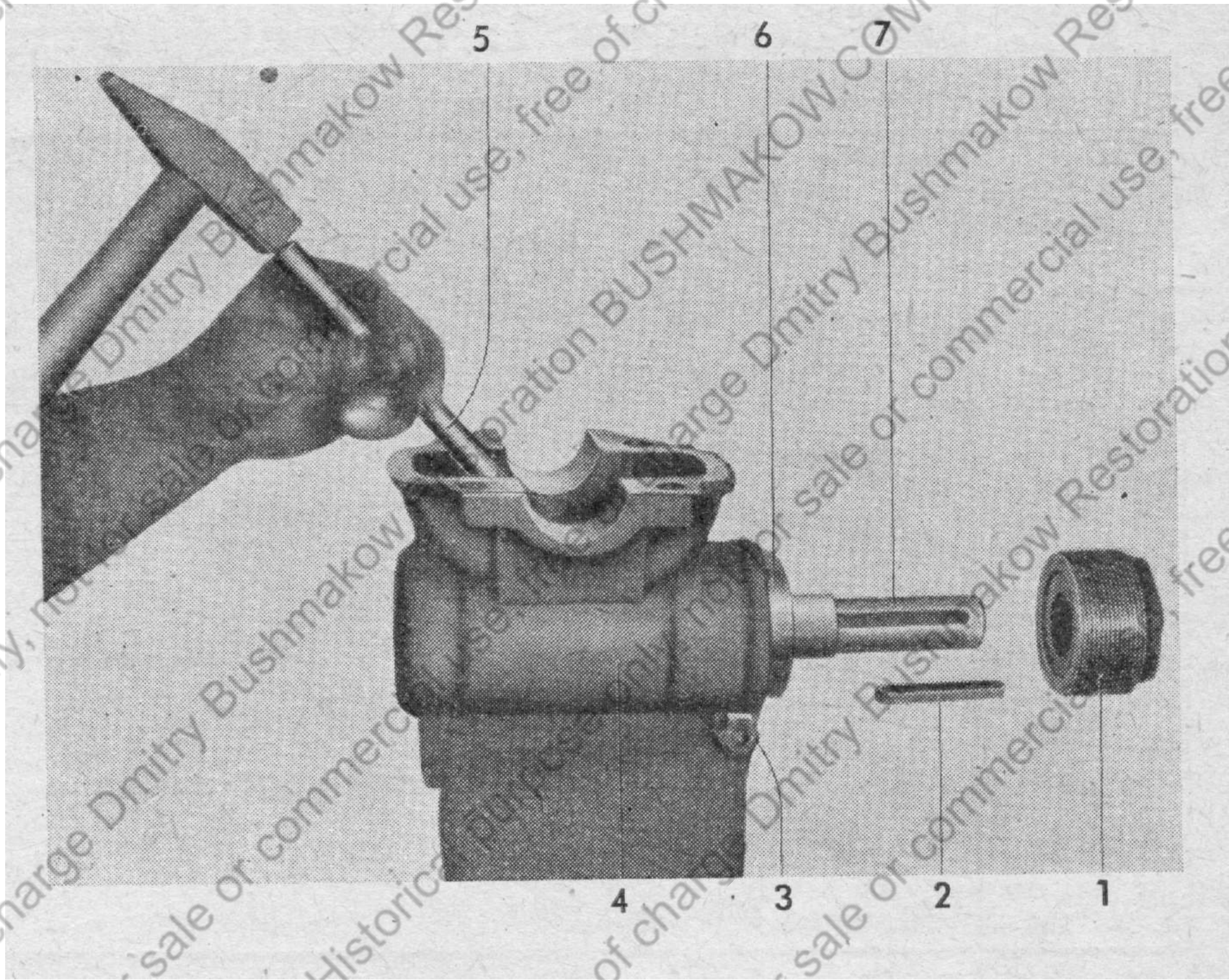
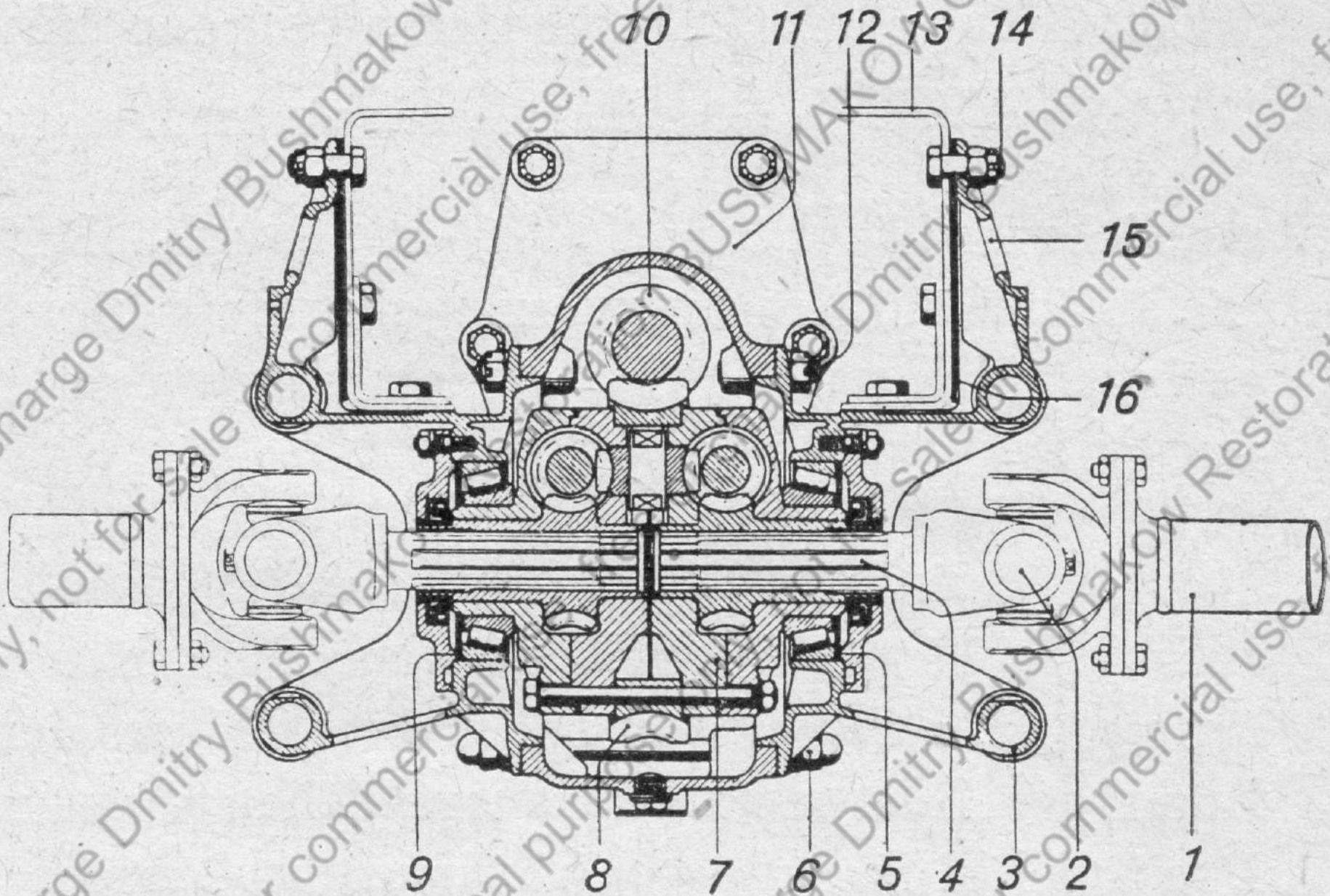

**Bild 62 Schnitt durch einen Achsantrieb**

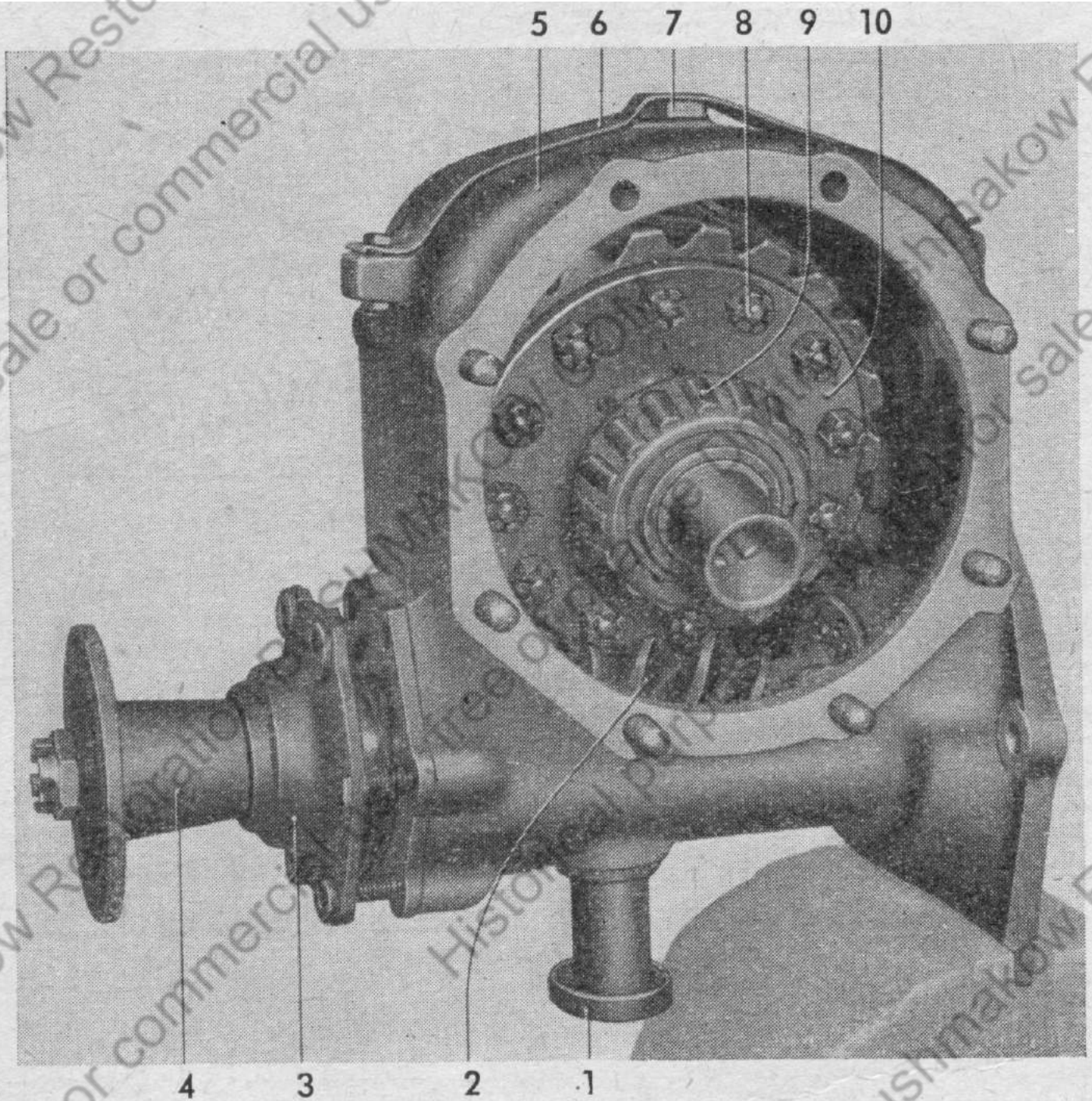

**Bild 63 Achsgehäuse mit Ausgleichgetriebe**



Bild 64

**Einlegen der Schnecken mit Bundbuchsen in die Gehäusebohrungen**

1 Gehäusehälfte

3 Antriebschneckenrad

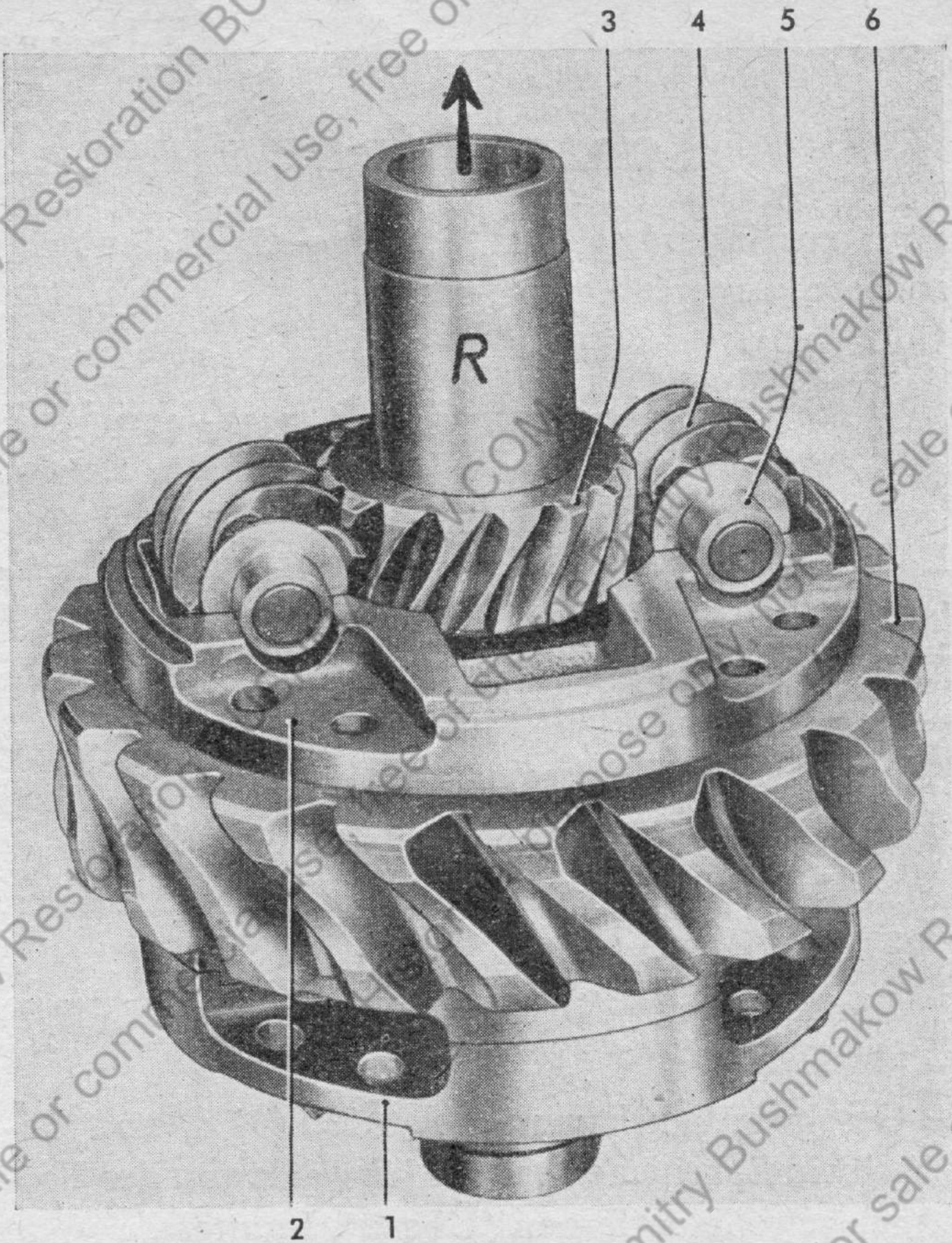
5 Bundbuchse

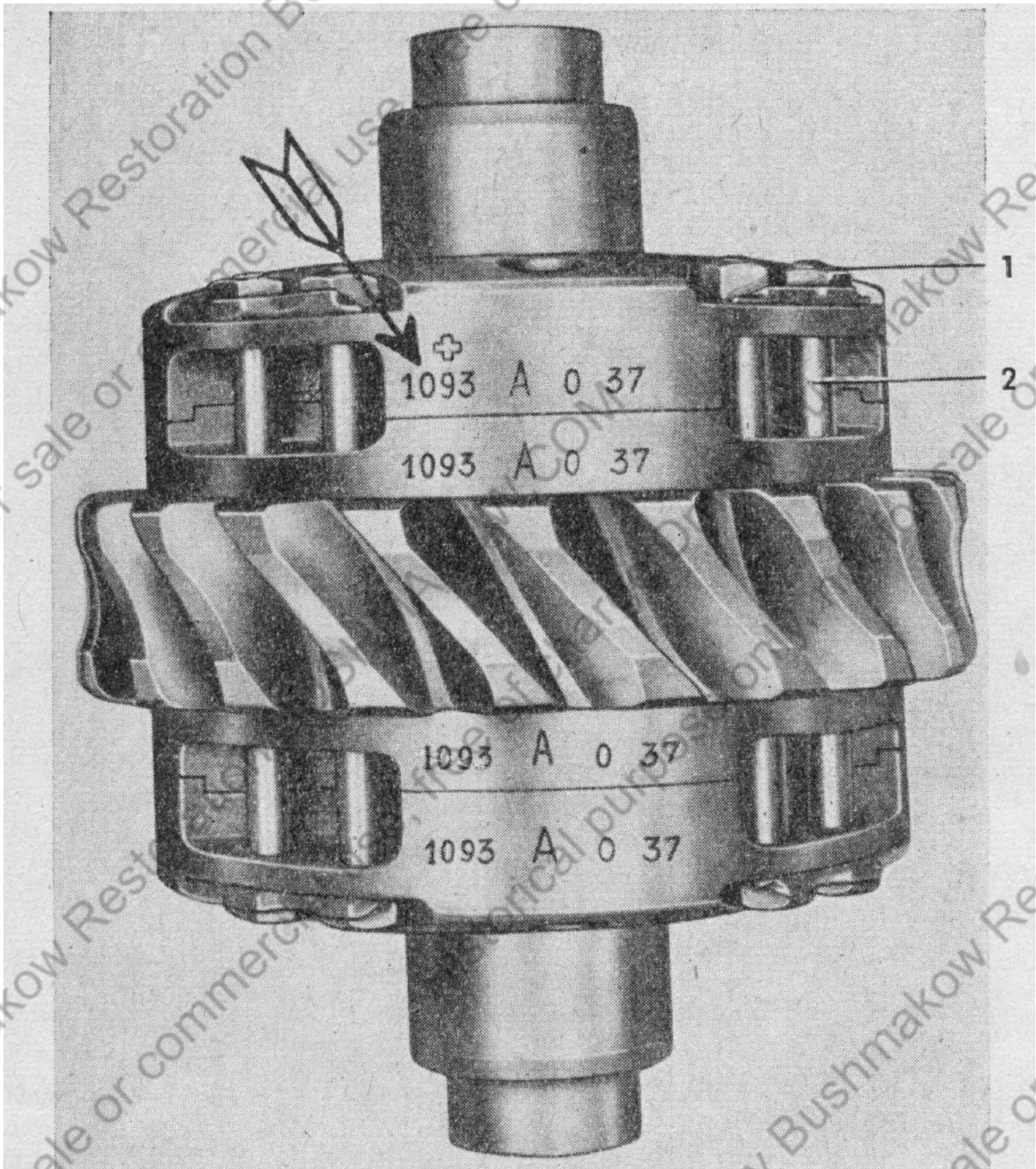

**Bild 65 Richtige Lage der Gehäuseteile zueinander**

1 Mutter

2 Schraube



Bild 66

**Andrücken der Bundbuchsen gegen die Gehäusewandungen**

1 Schraube

2 Mutter

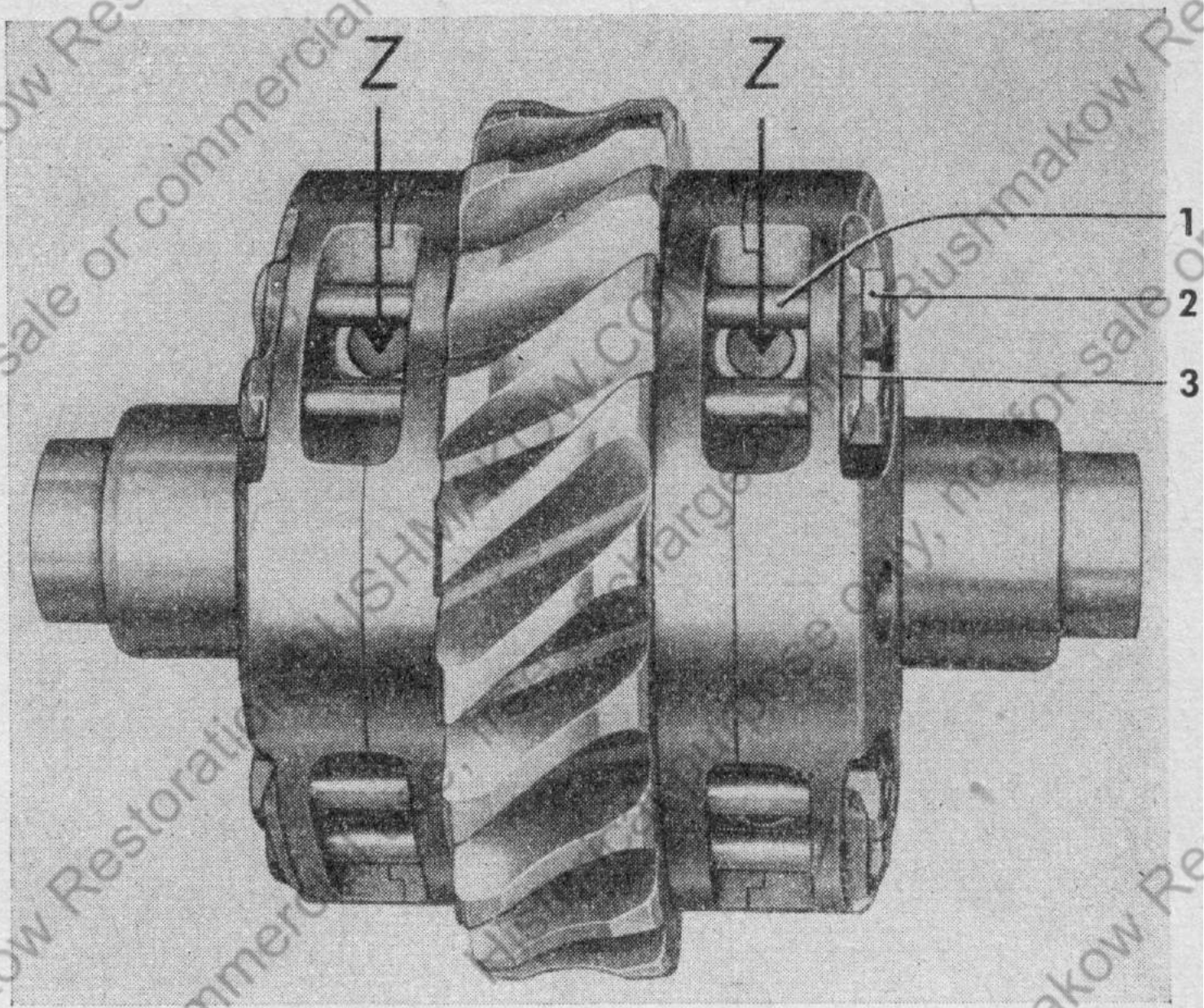
3 Sicherungsblech



Bild 67

**Andrücken der Bundbuchsen gegen die Gehäusewandungen**

1 Gehäuseschraube

3 Sperrschnecke

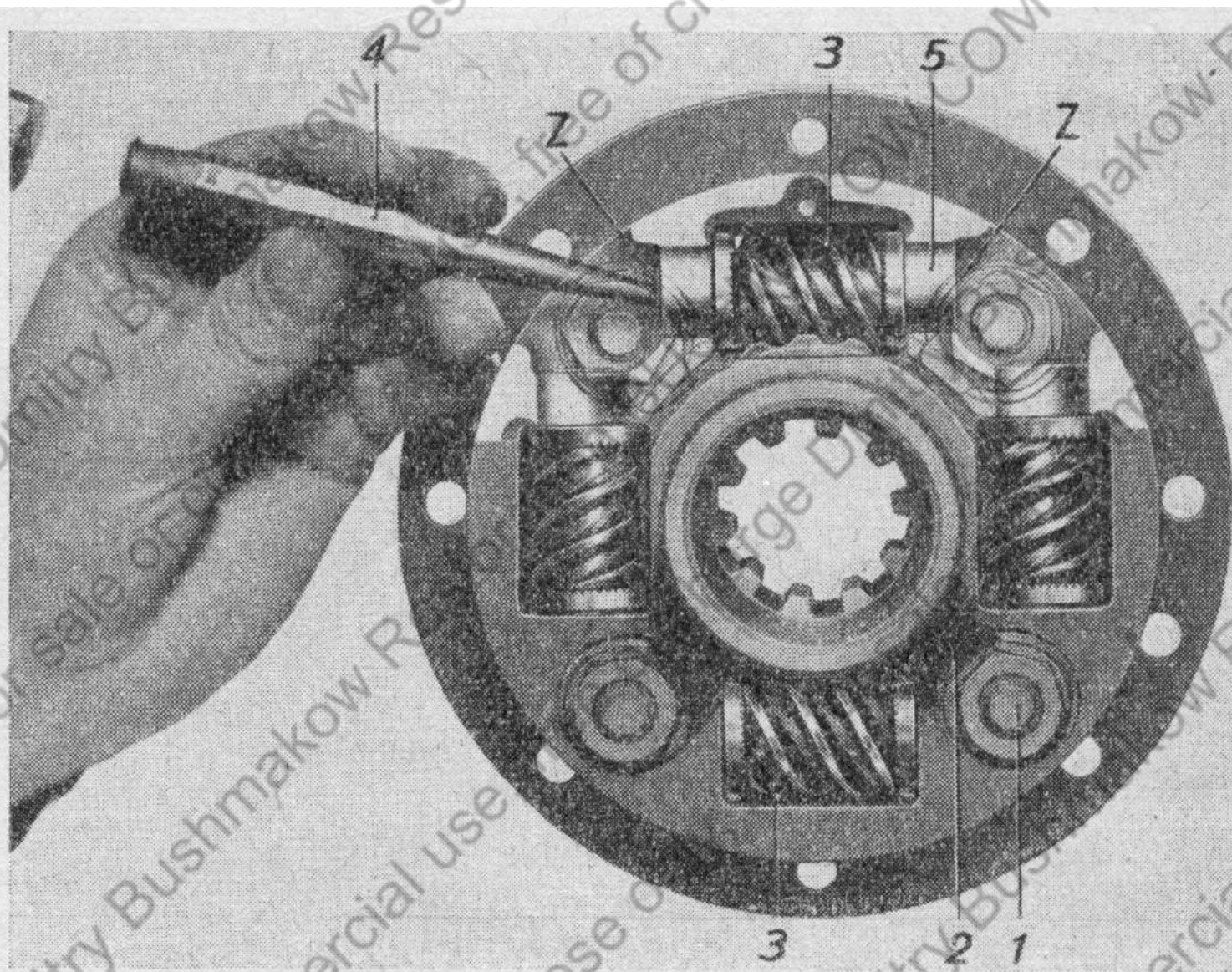
5 Bundbuchse

9

10

11

12

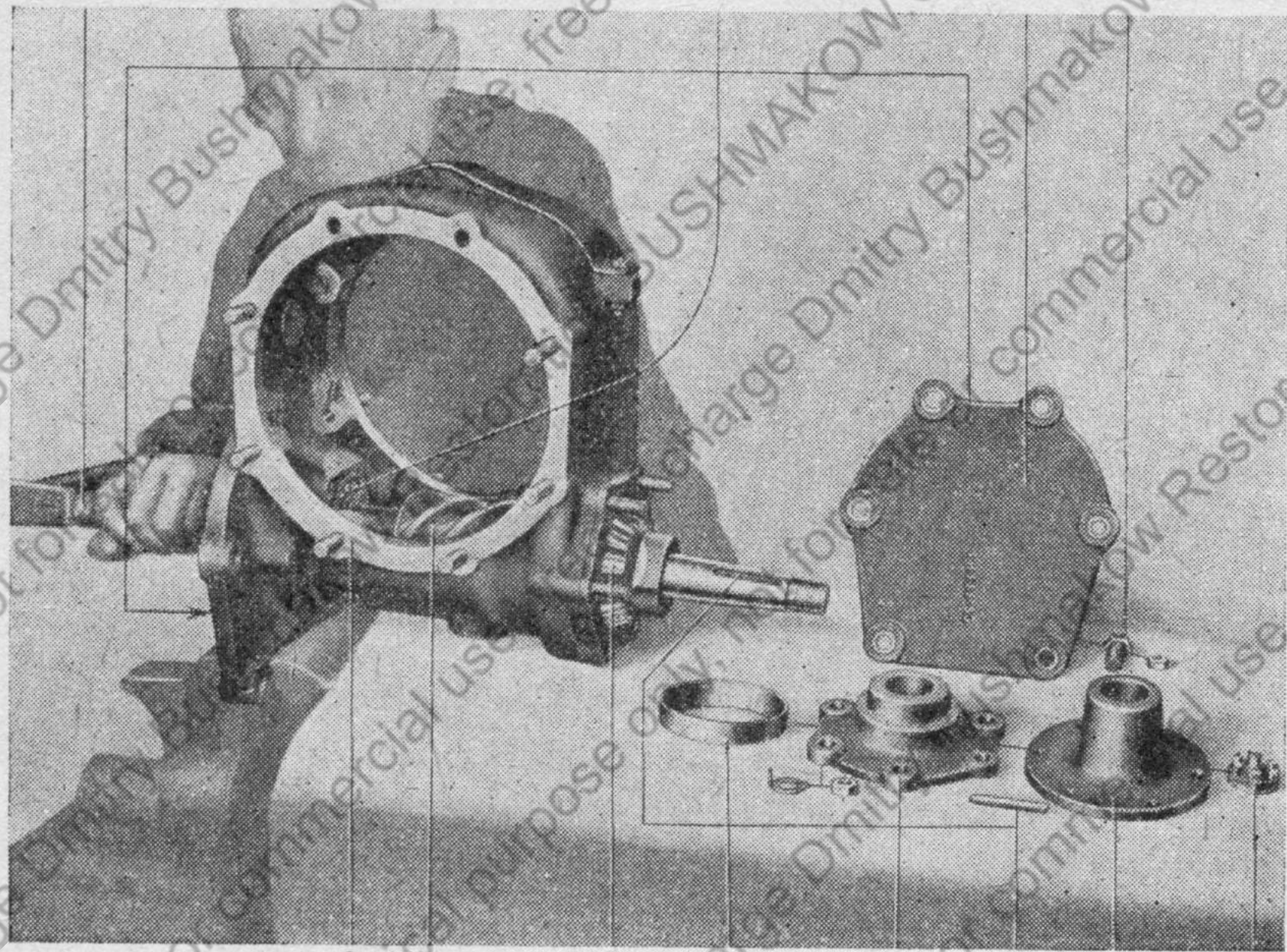

8

7

6

5

4

3

2

1



10

11

12

13

14

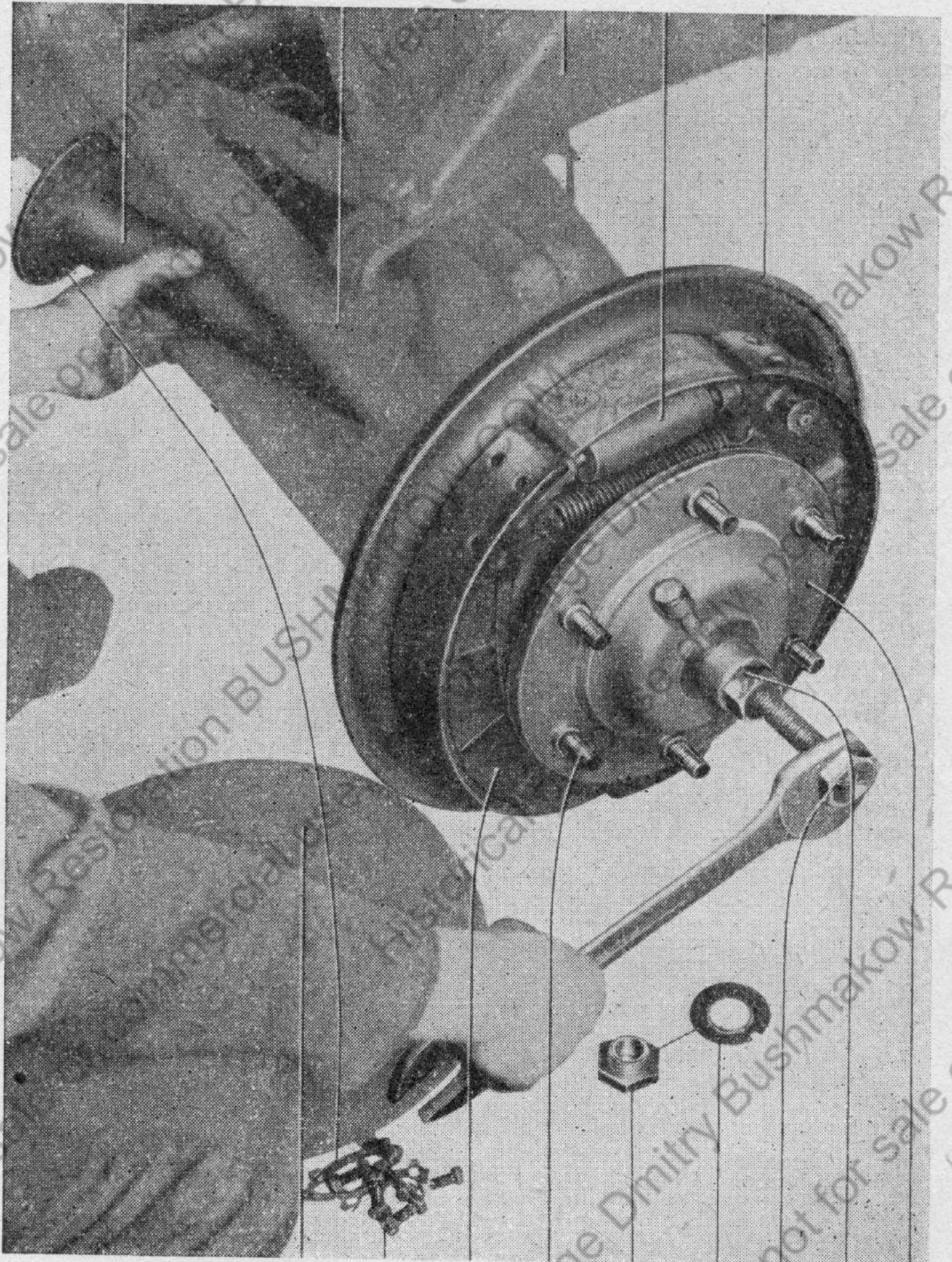

9

8

7

6

5

4

3

2

1



Bild 70 Querlenker ausbauen

1. Durchschle...

2. D...

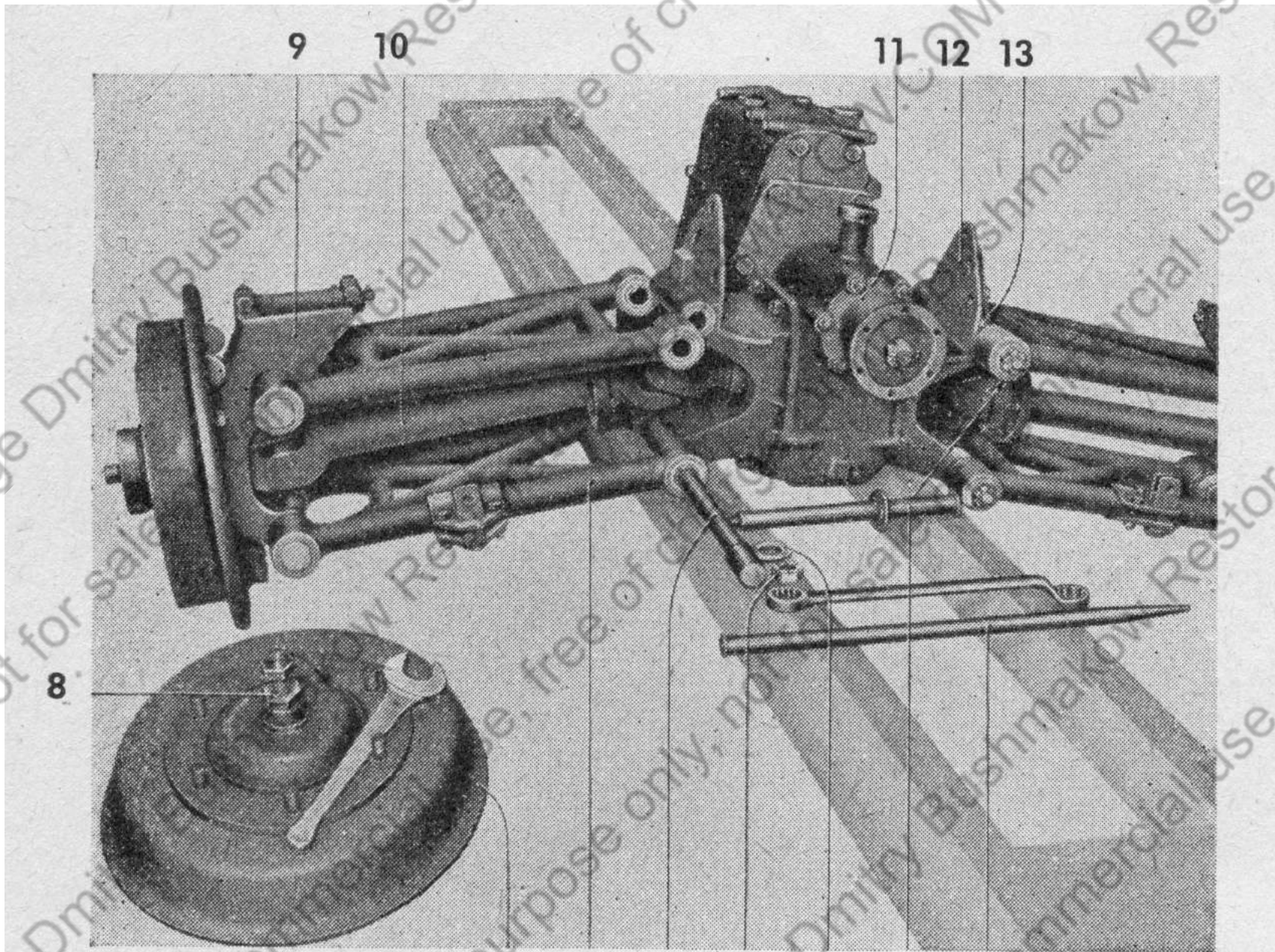
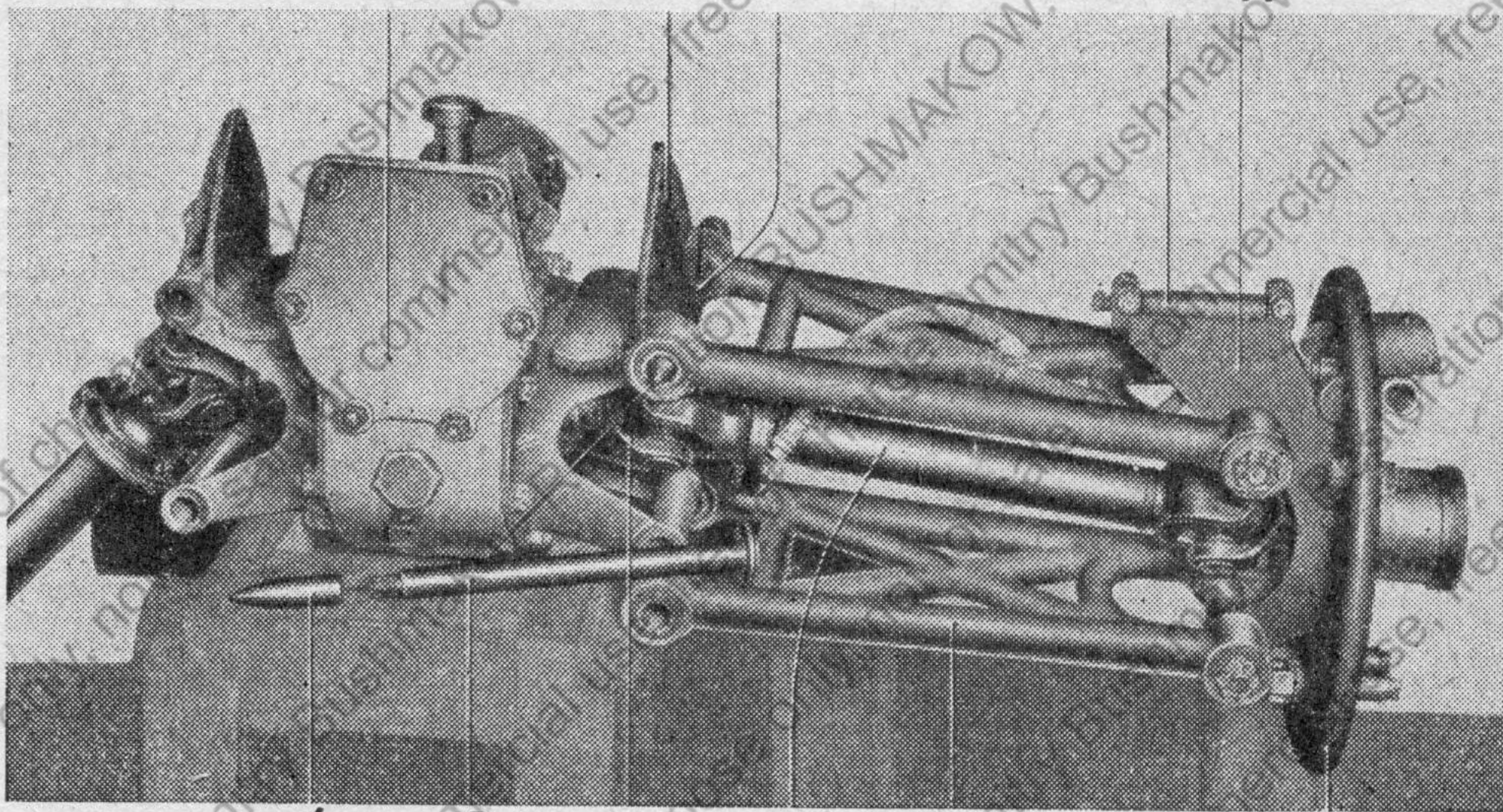

**Bild 71 Querlenker einbauen**

1 Bremshalter

7 Achsentrieb

9 10 11 12 13 14

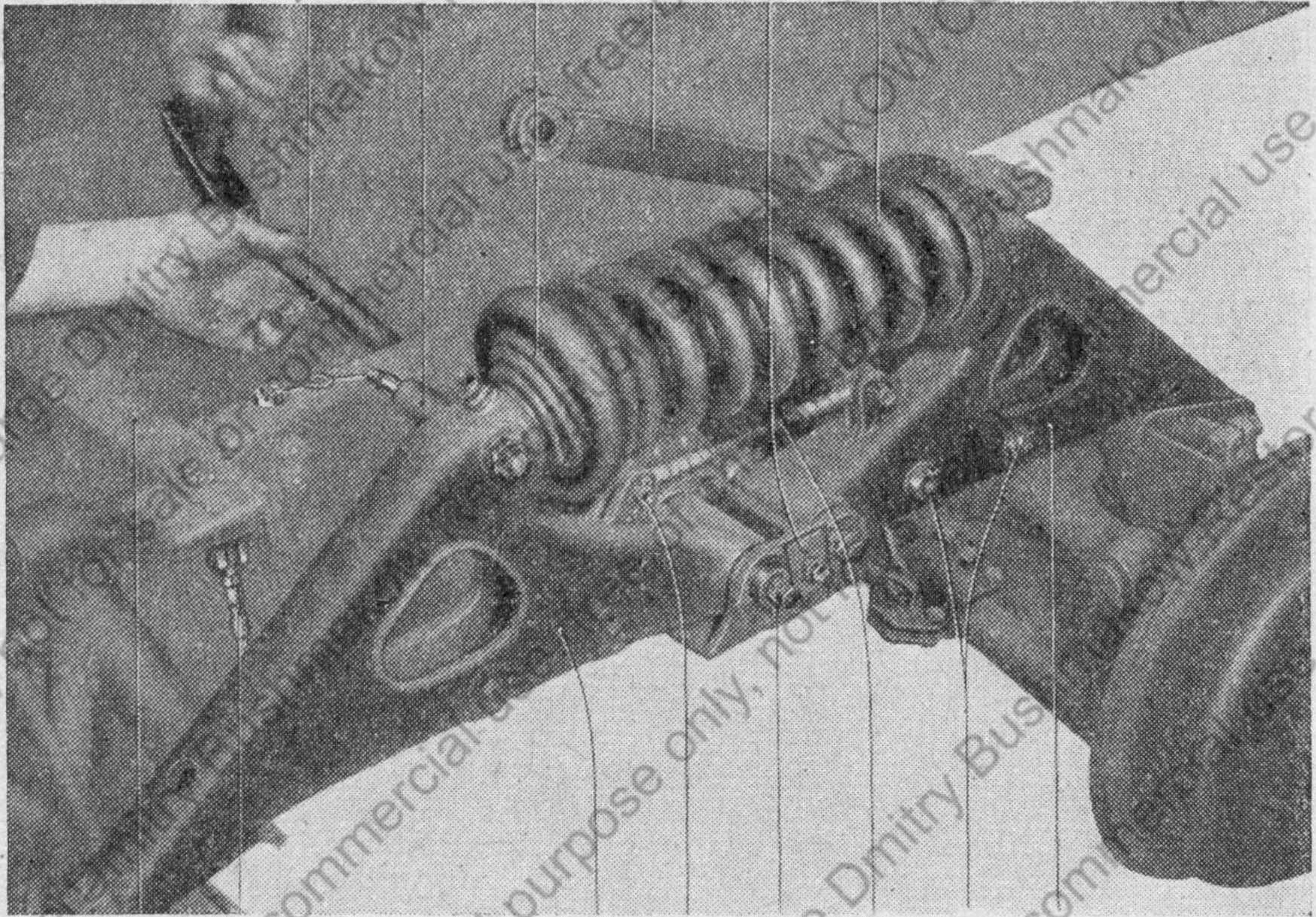

8 7 6 5 4 3 2 1

**Bild 72 Hinterfeder ausbauen**



Bild 73 Hinterer Stoßdämpfer



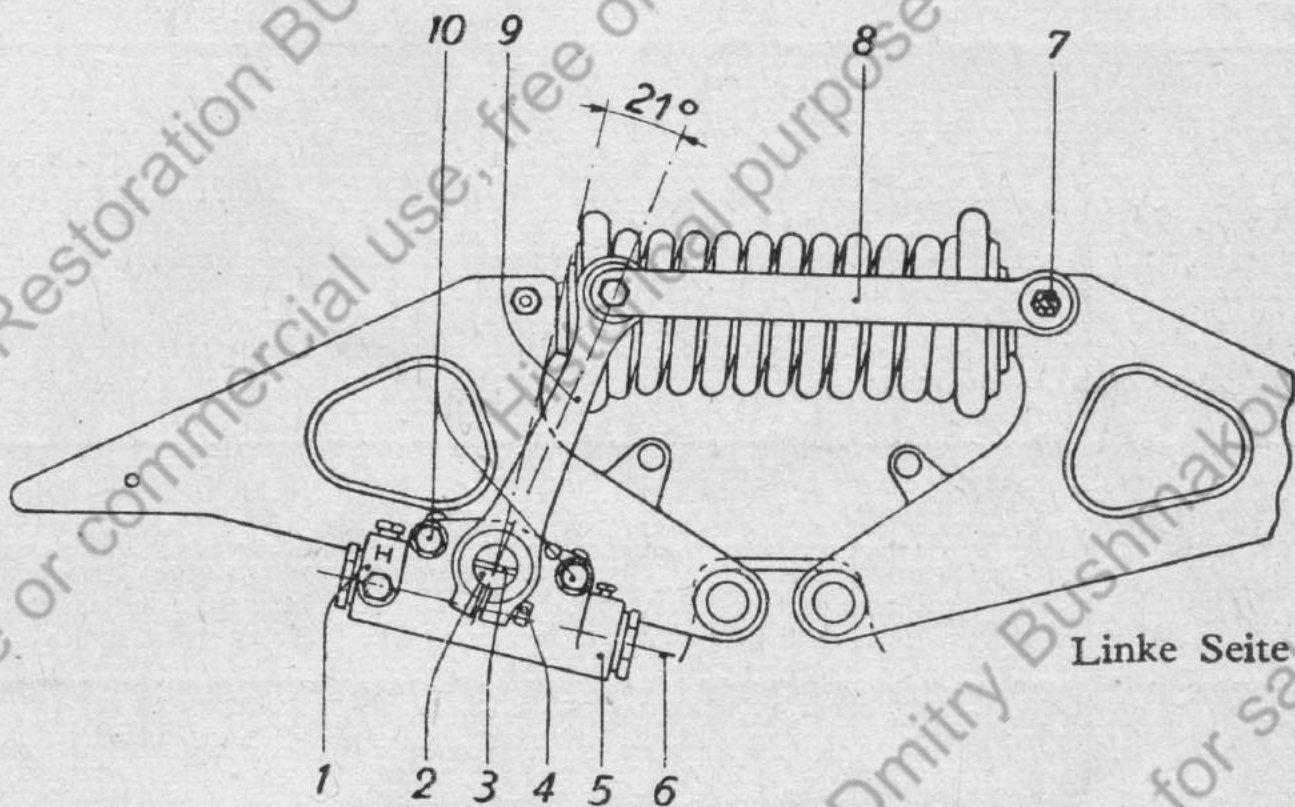
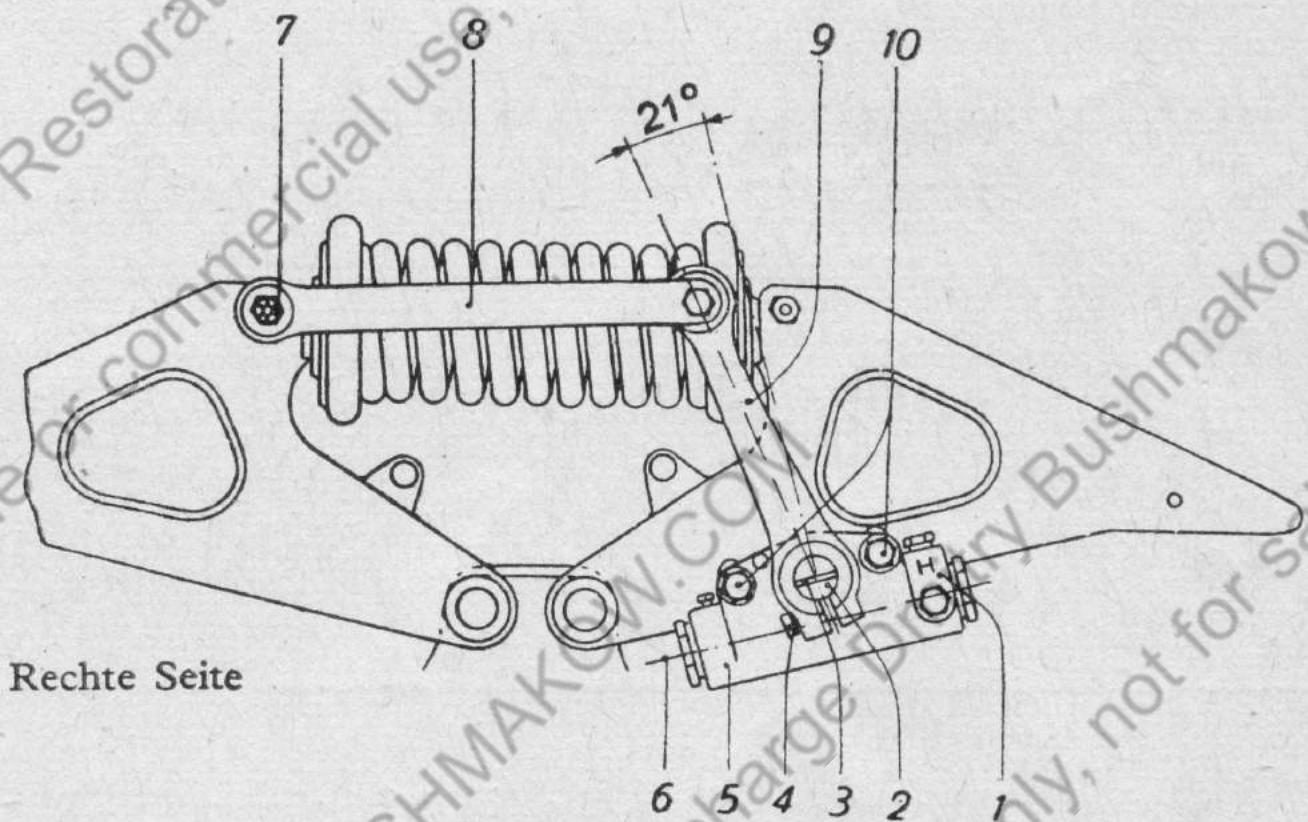
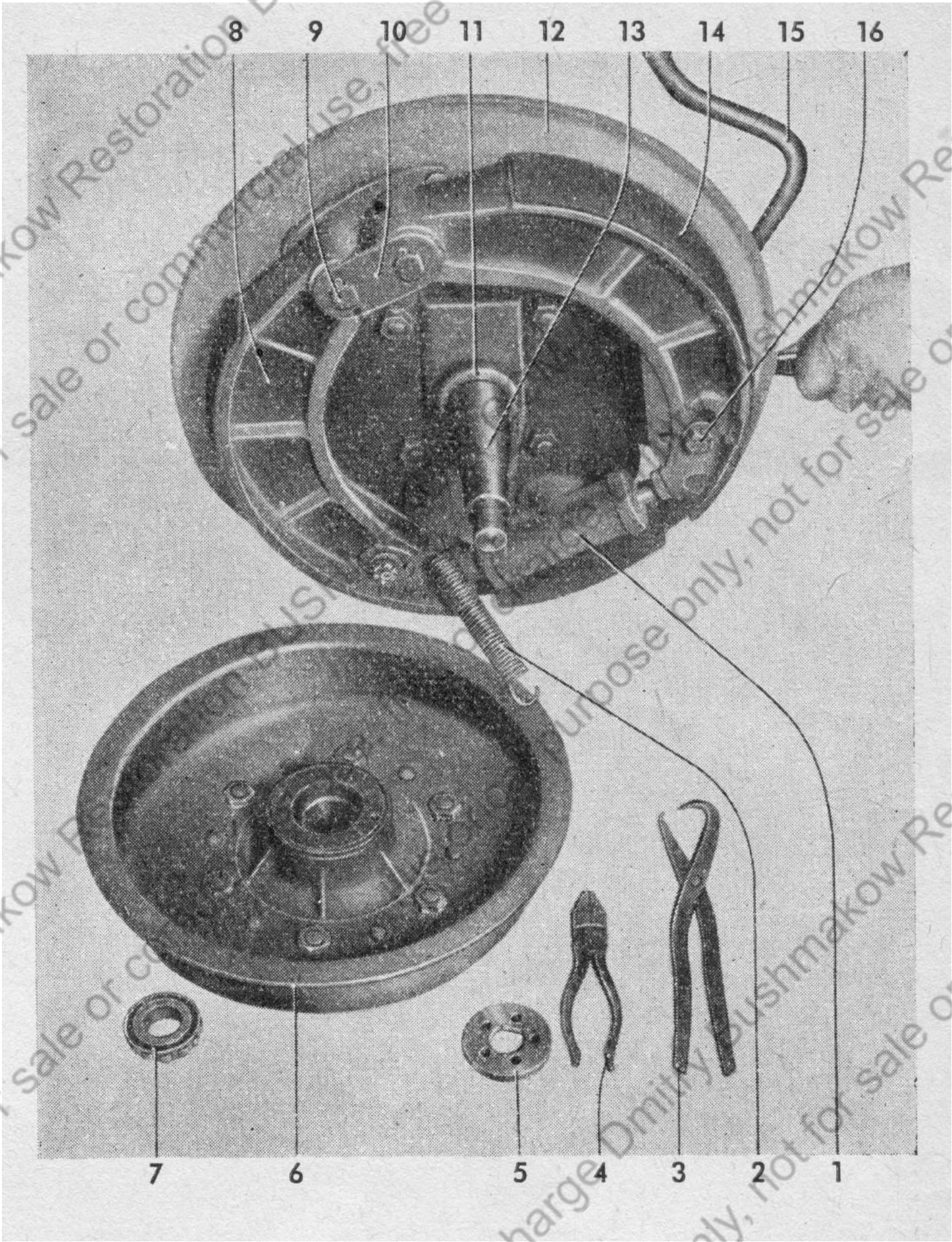
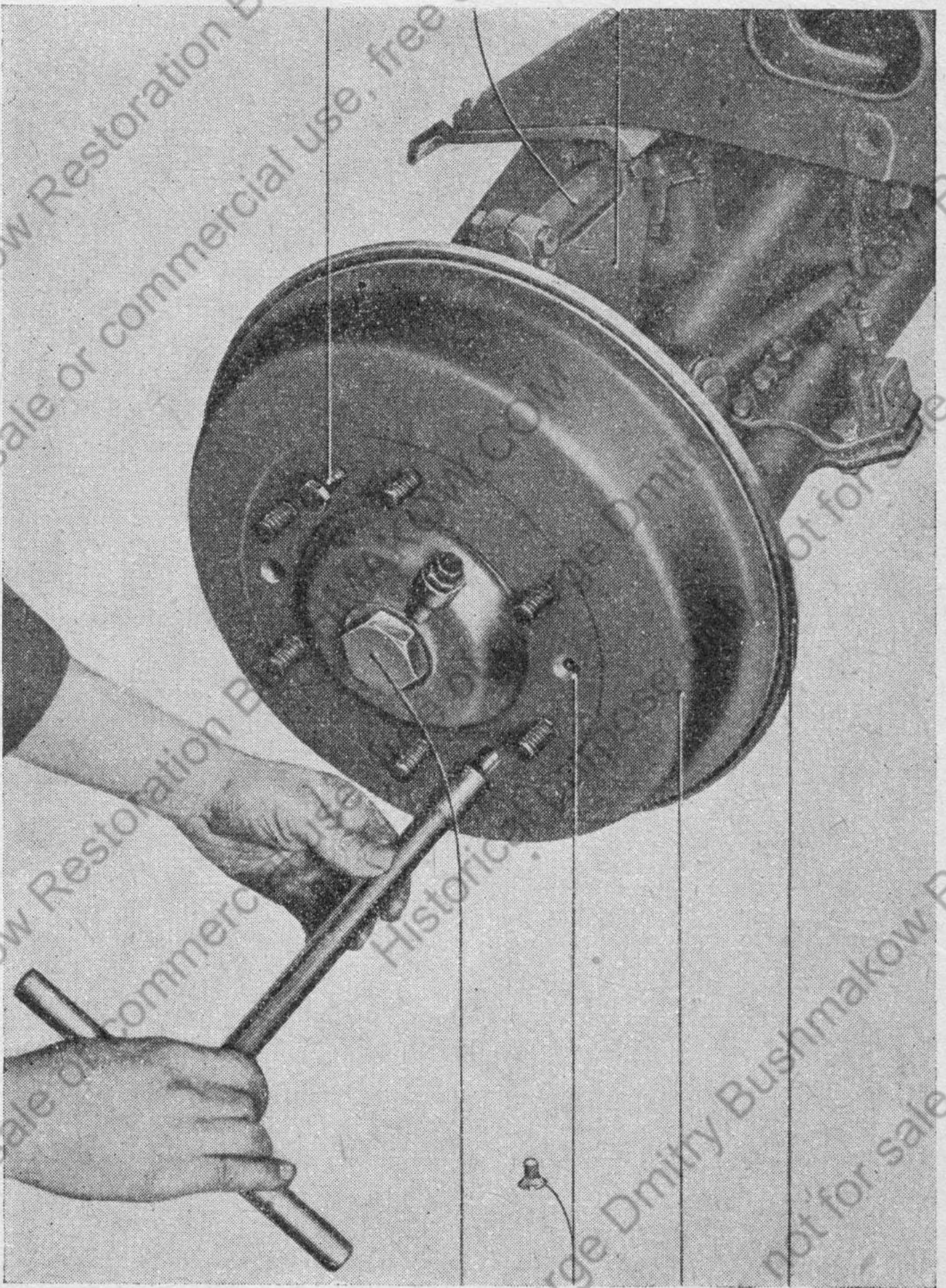

5

6

7

4

3

2

1







Bild 77 Hauptzylinder



Bild 78 Radbremszylinder

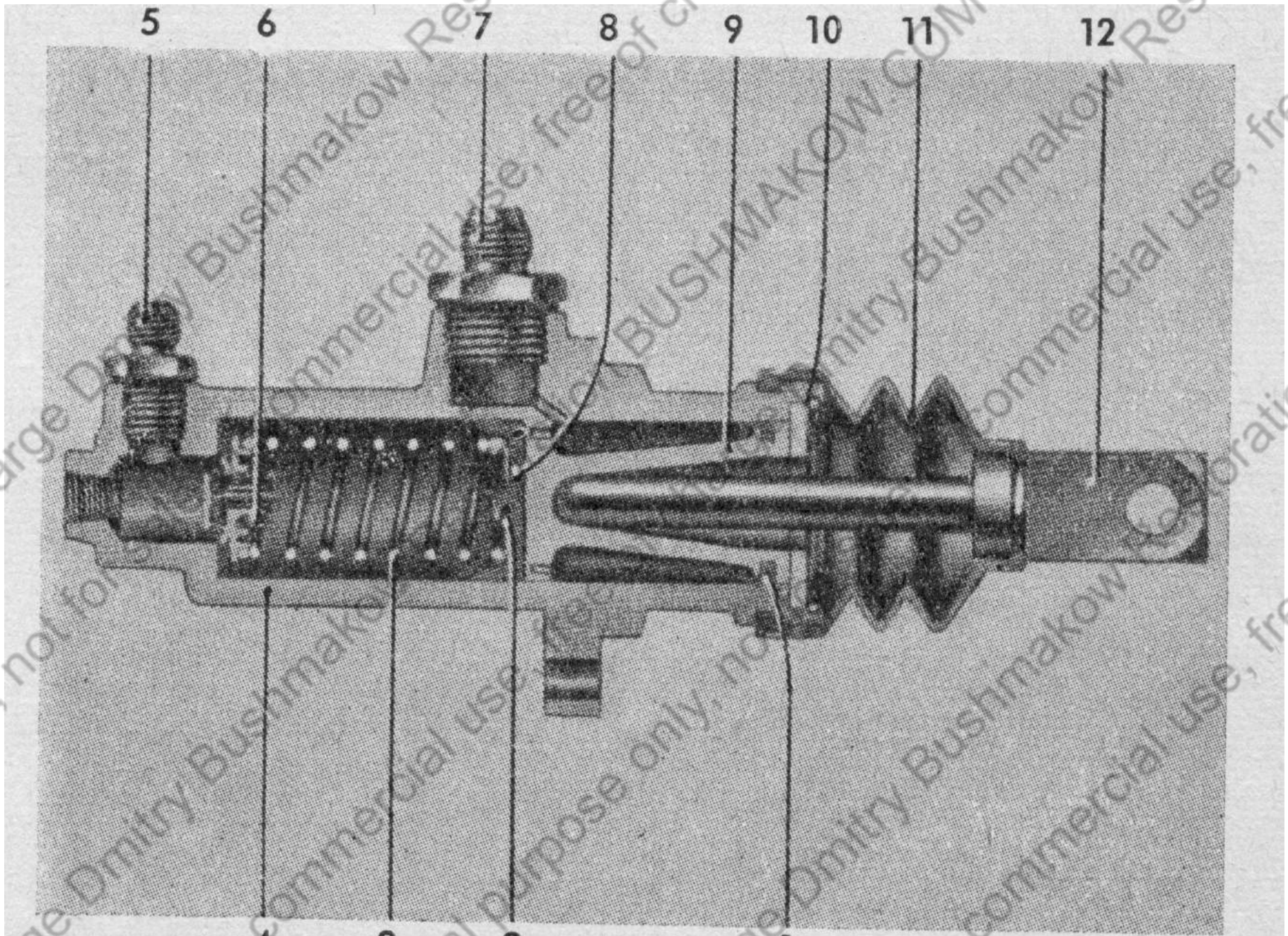

**Bild 79 Vorderradnabe ausbauen**

1 Drehstift

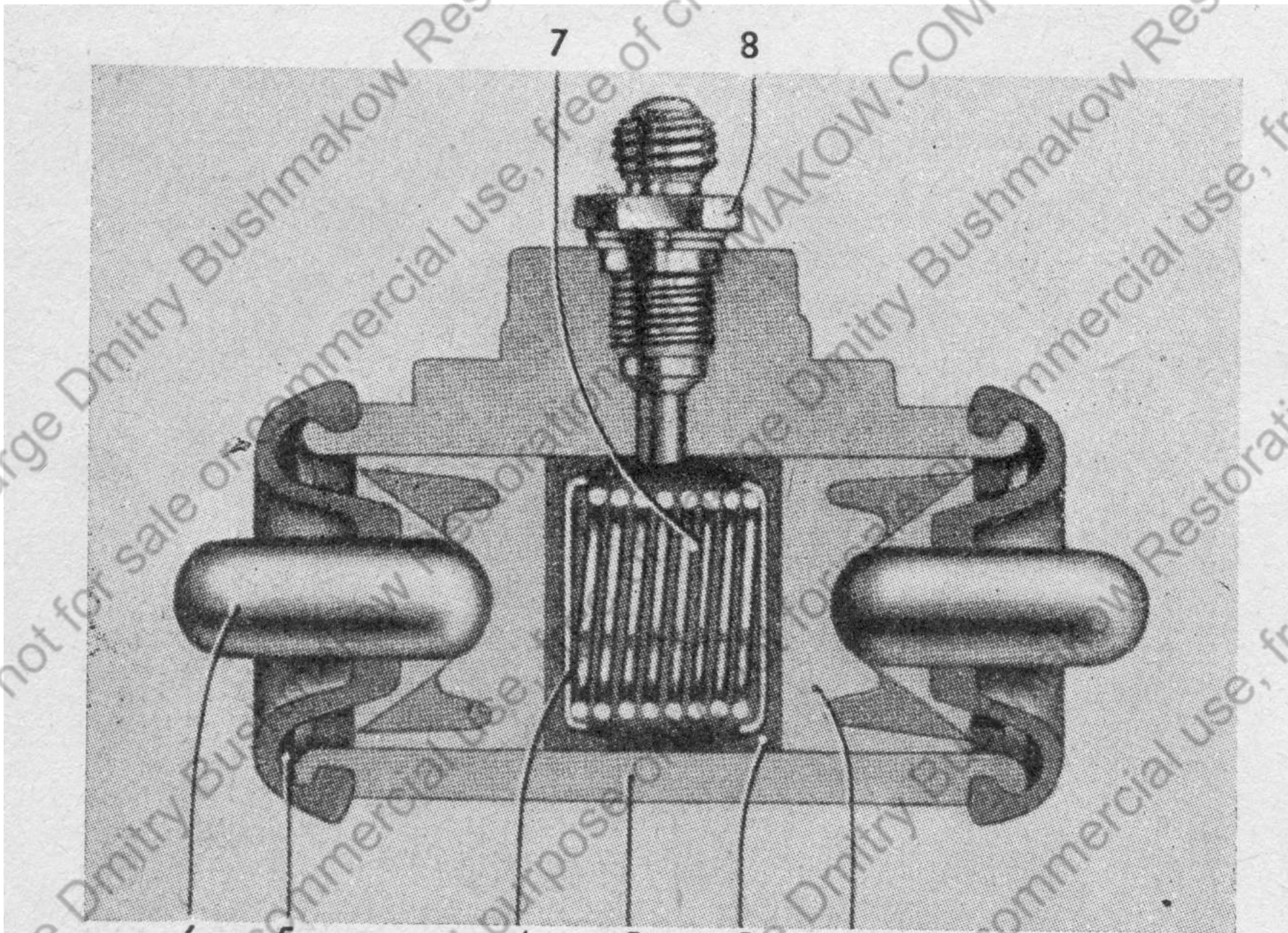
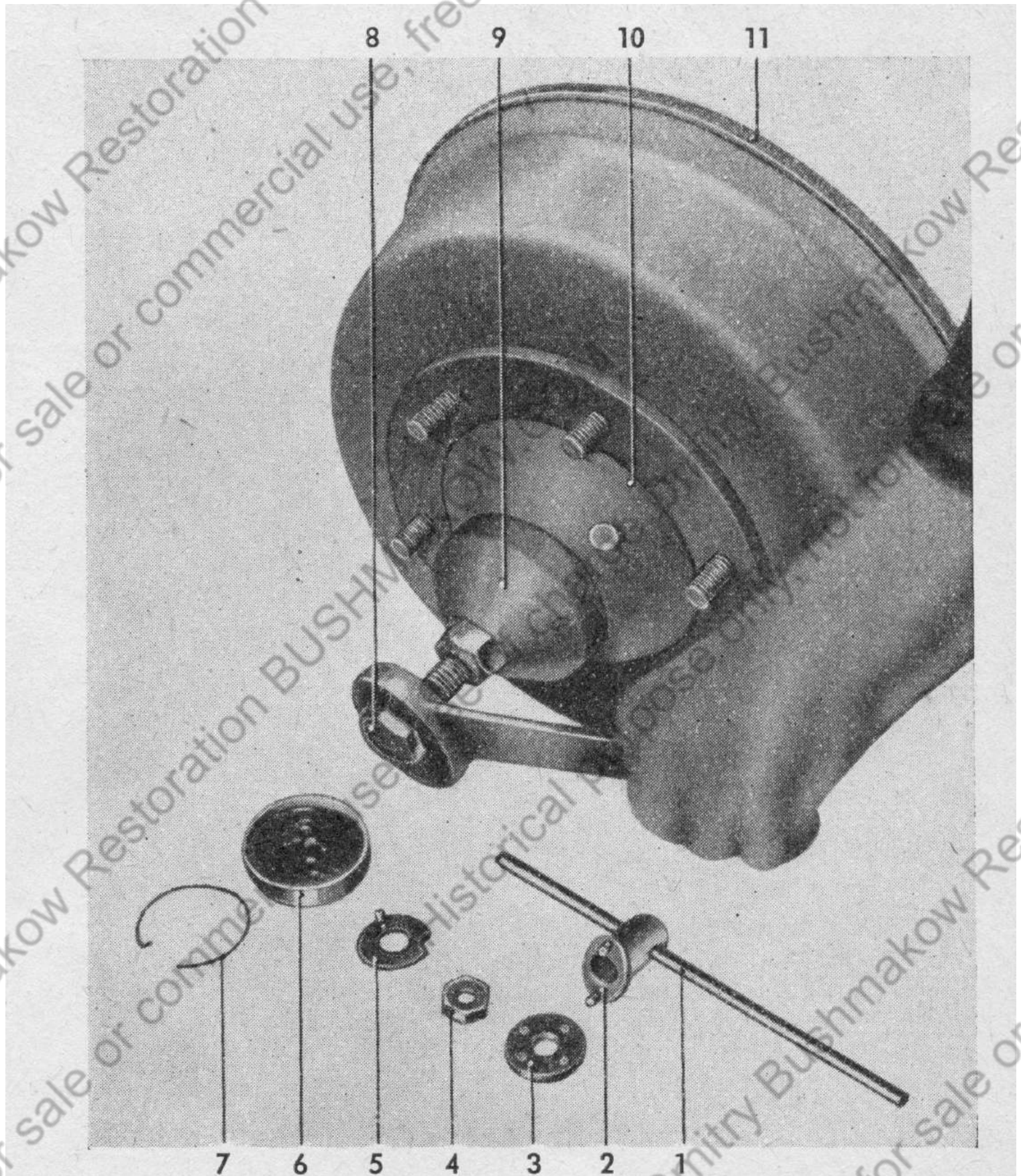
7 Hebenring

10

11

12

13



Bild 80 Hinterradnabe ausbauen



**Bild 81 Anhängerkupplung**

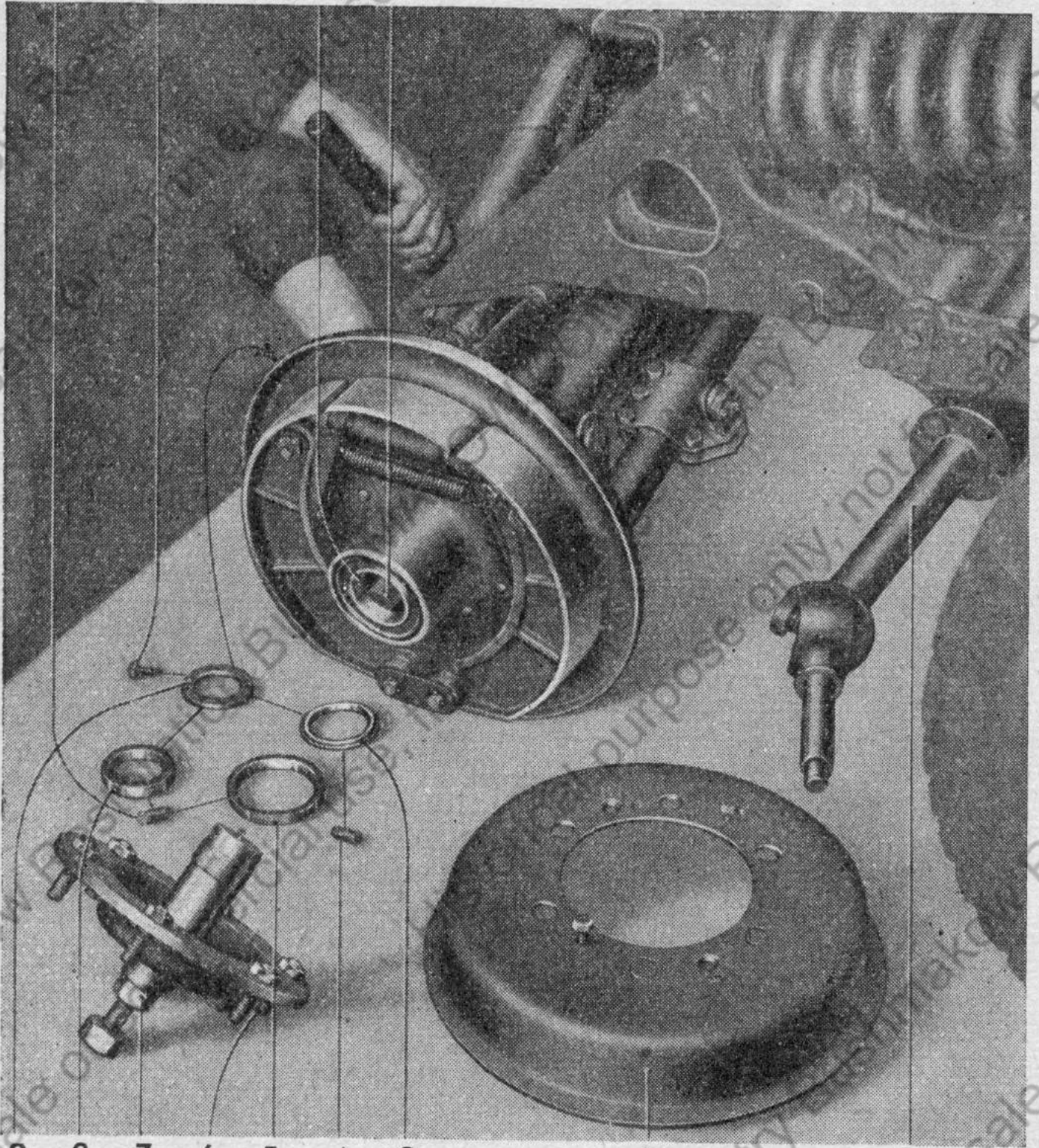
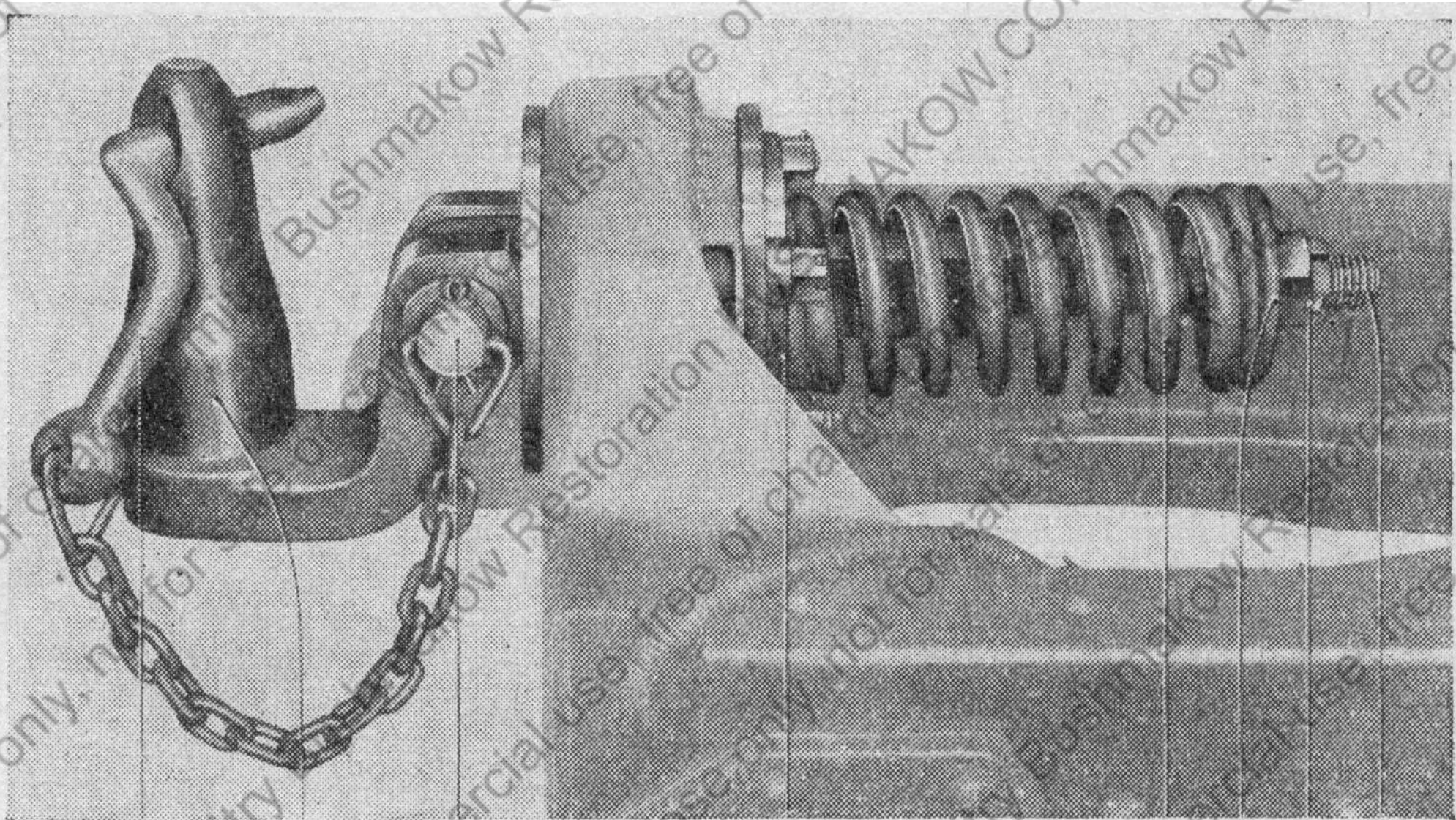
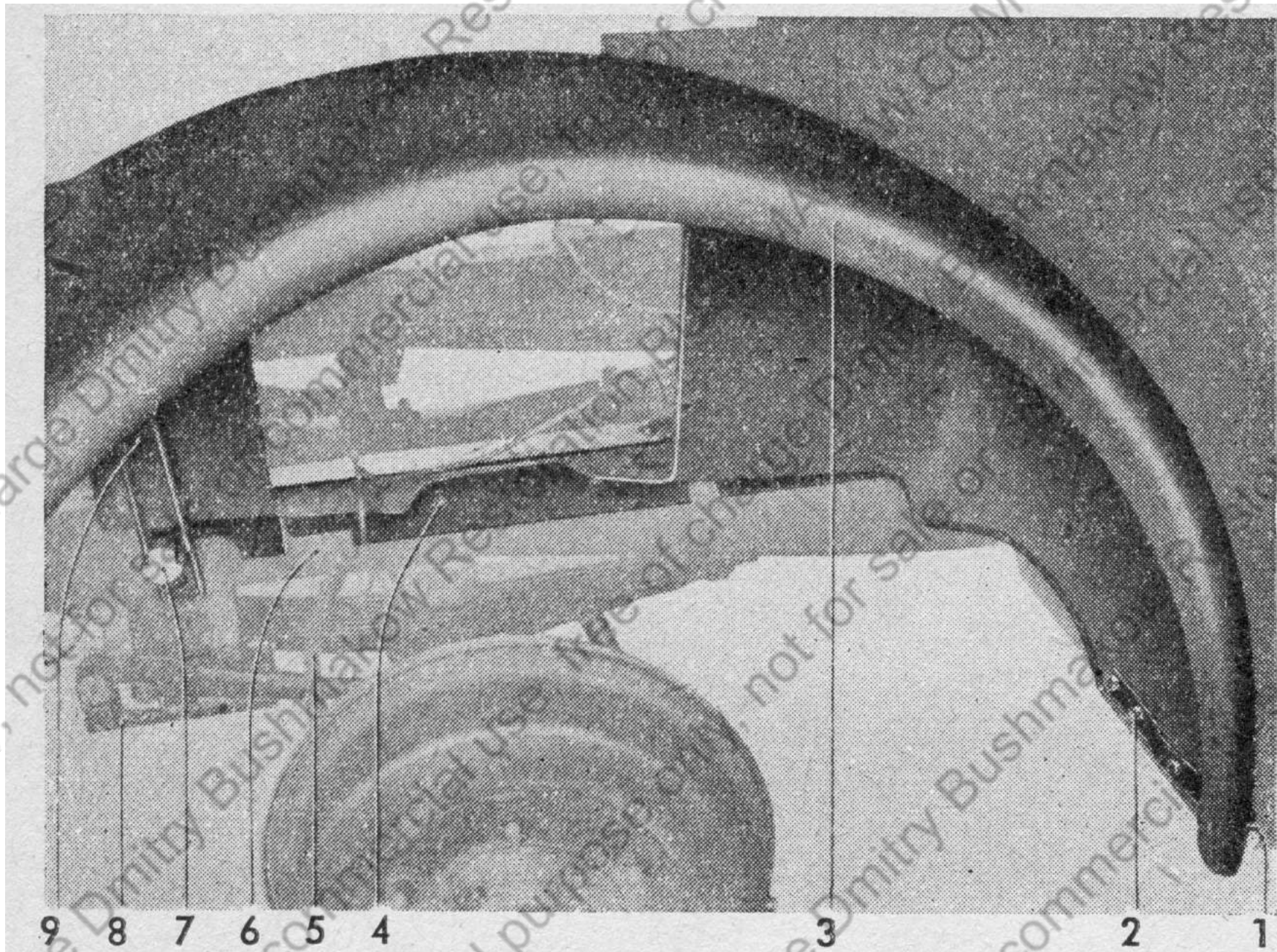

**Bild 82 Kotflügel abbauen**

1 Kotflügelhalter

6 Halter zum Bremsschlauch



Bild 92 Plenelektrischer Chassis





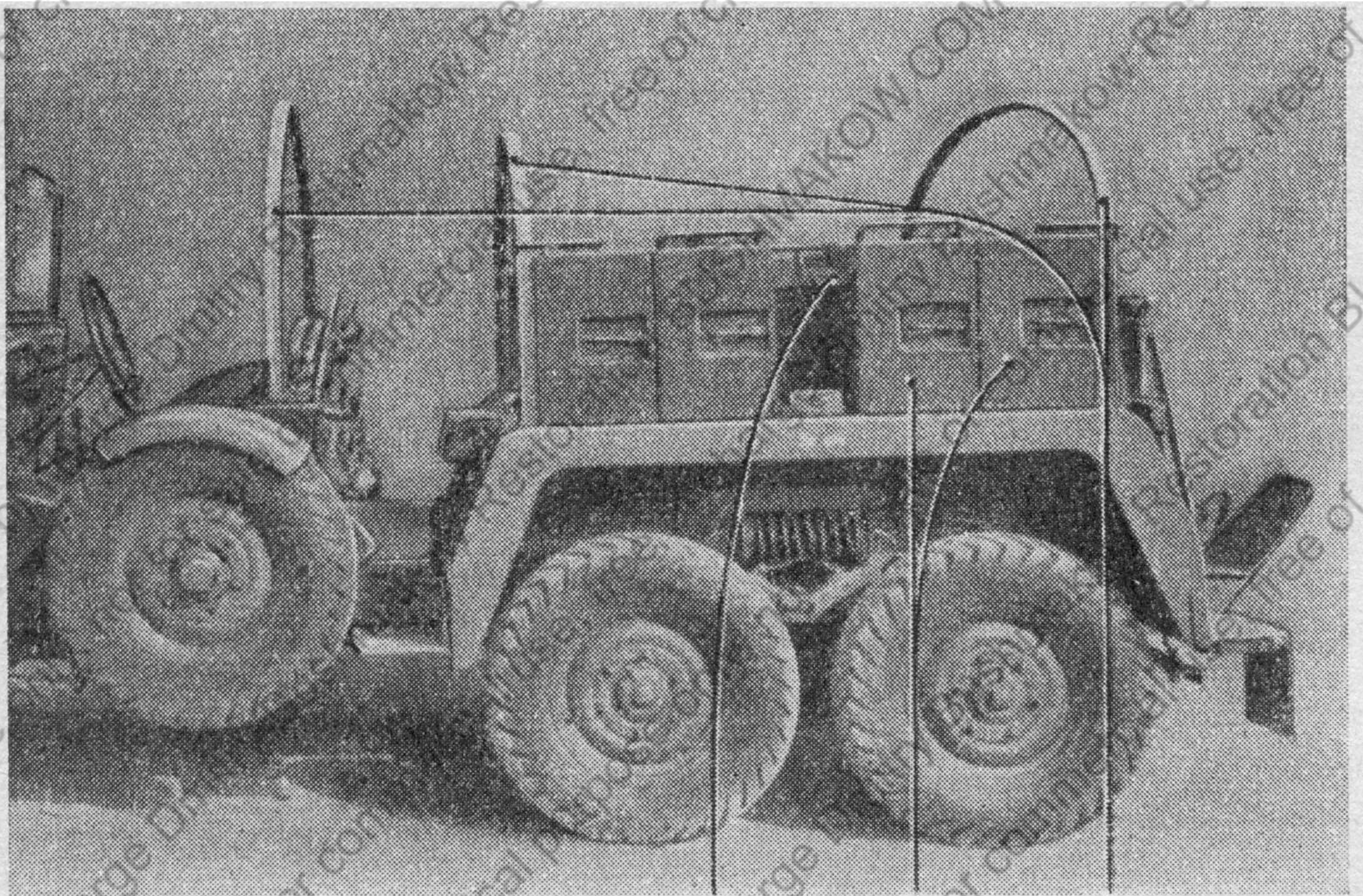
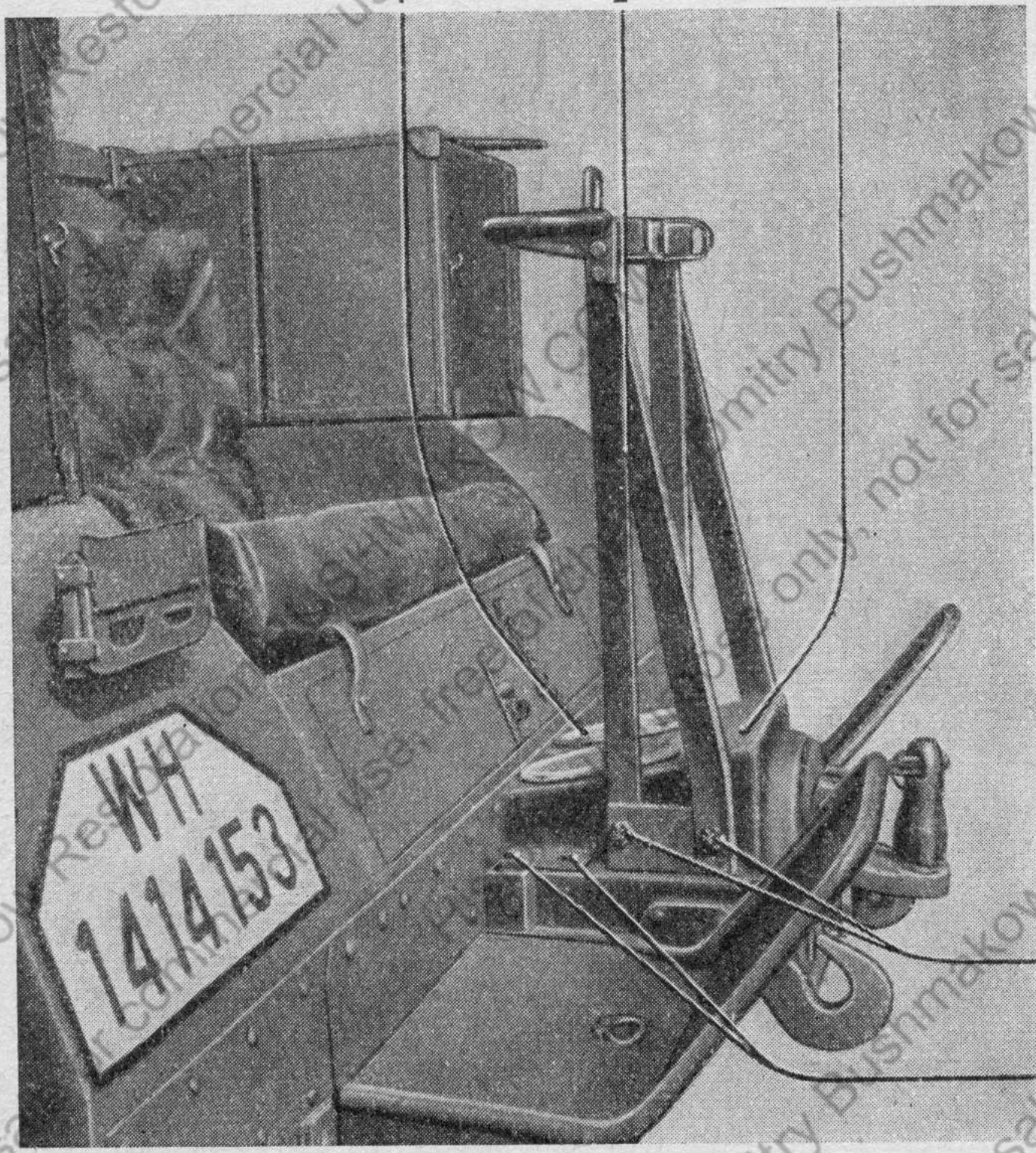
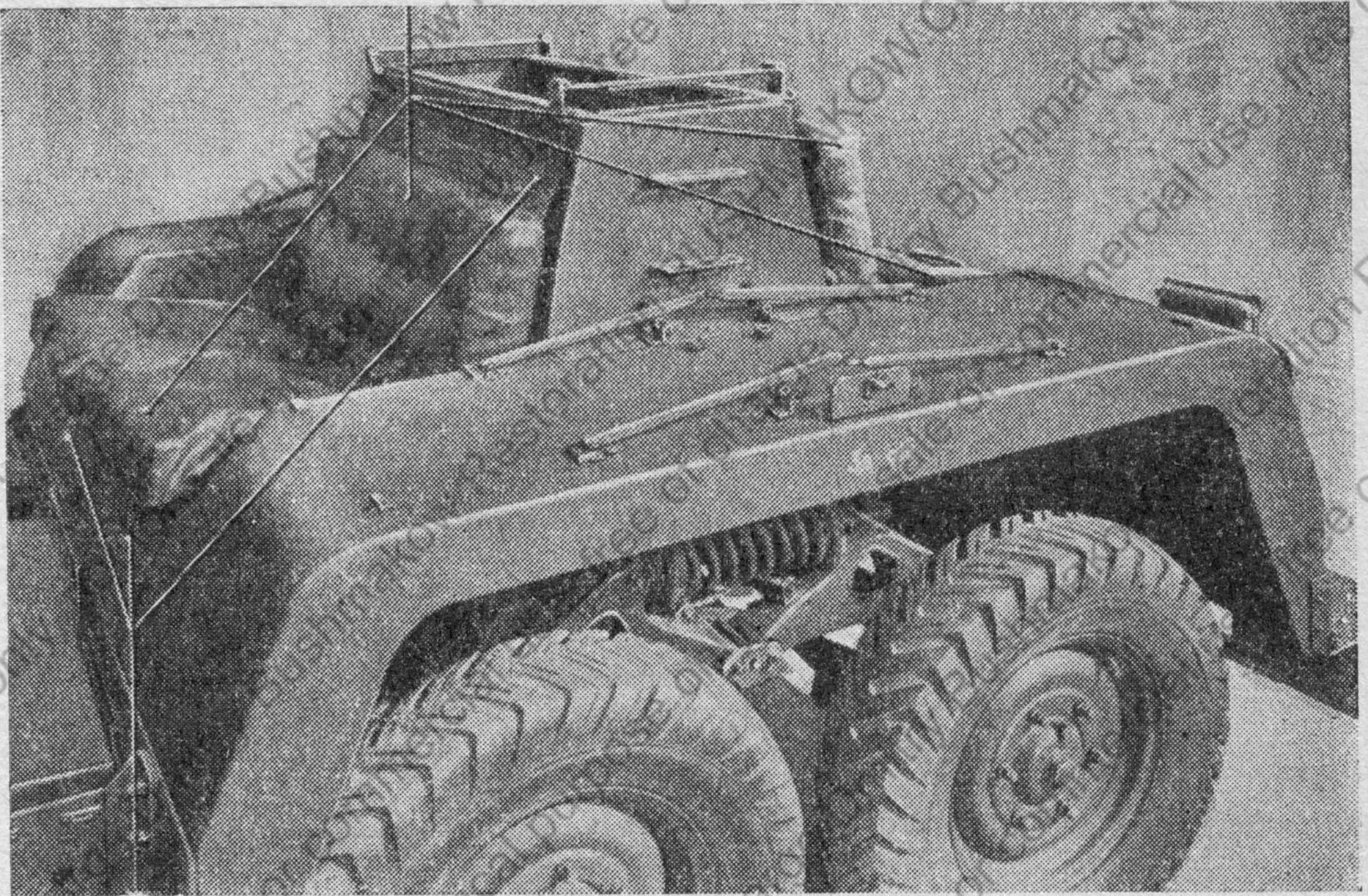

1

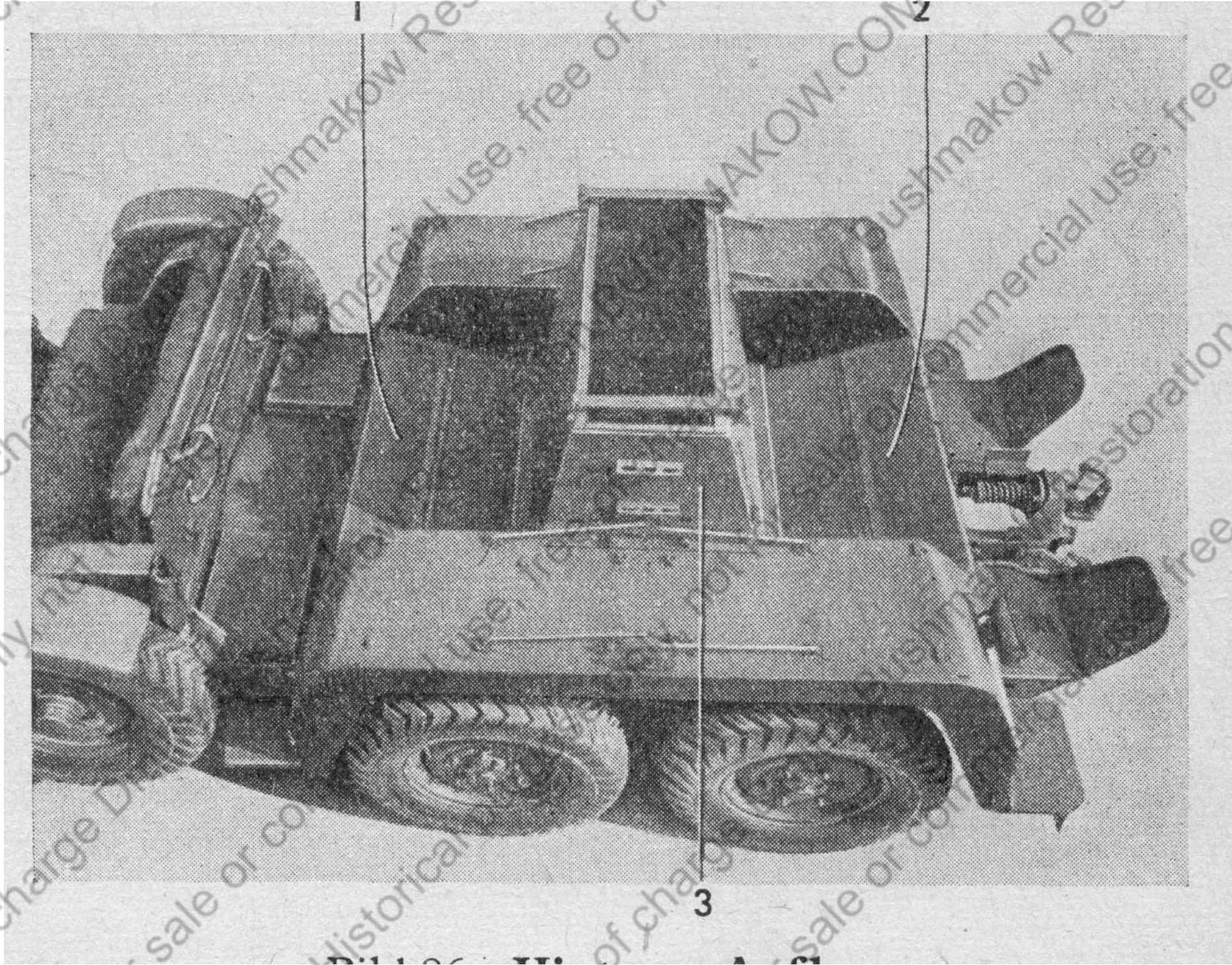

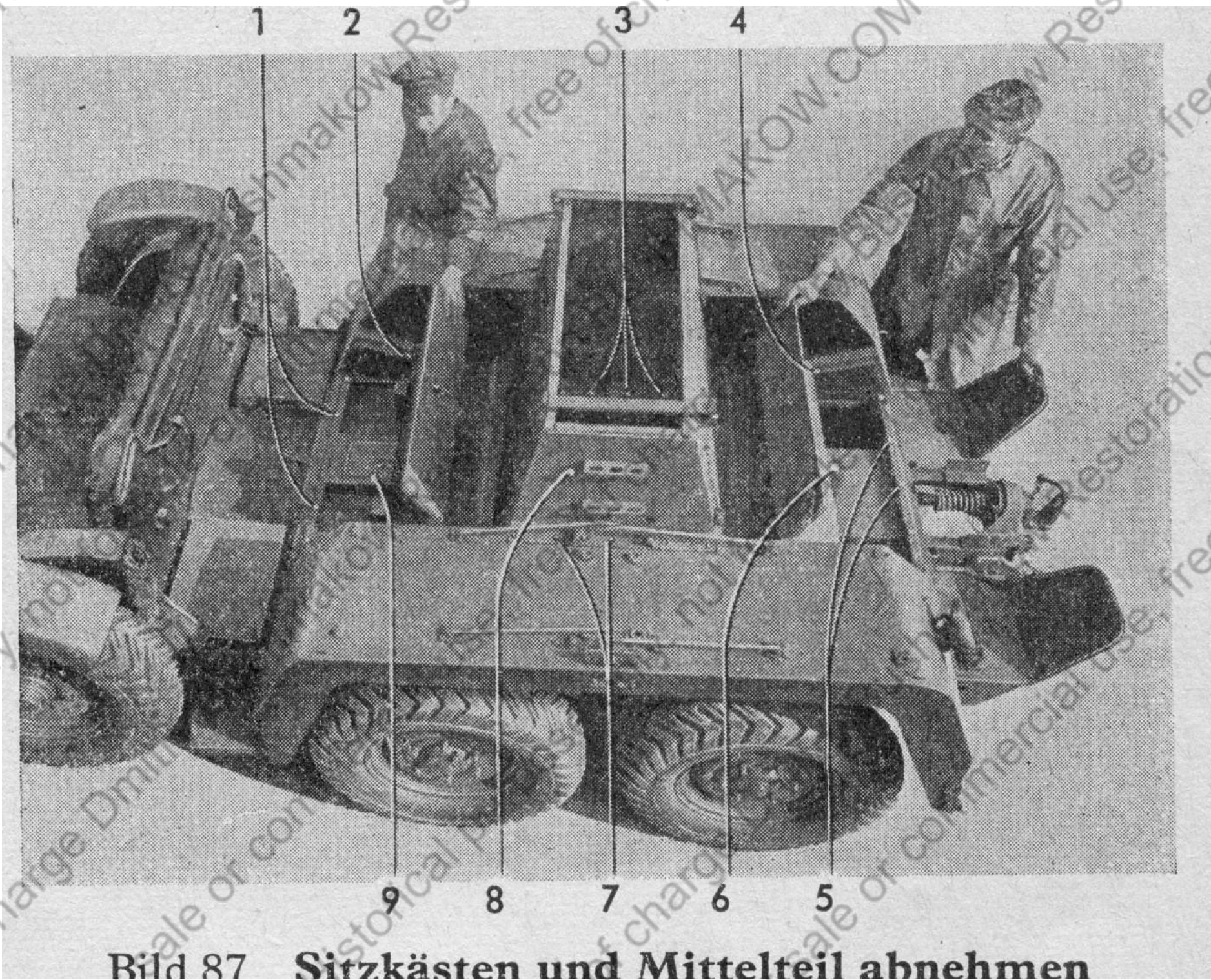

**Bild 87 Sitzkästen und Mittelteil abnehmen**



Bild 90 Aufbauvorderteil



Bild 88



**Bild 89**    **Einhängen der Seile**

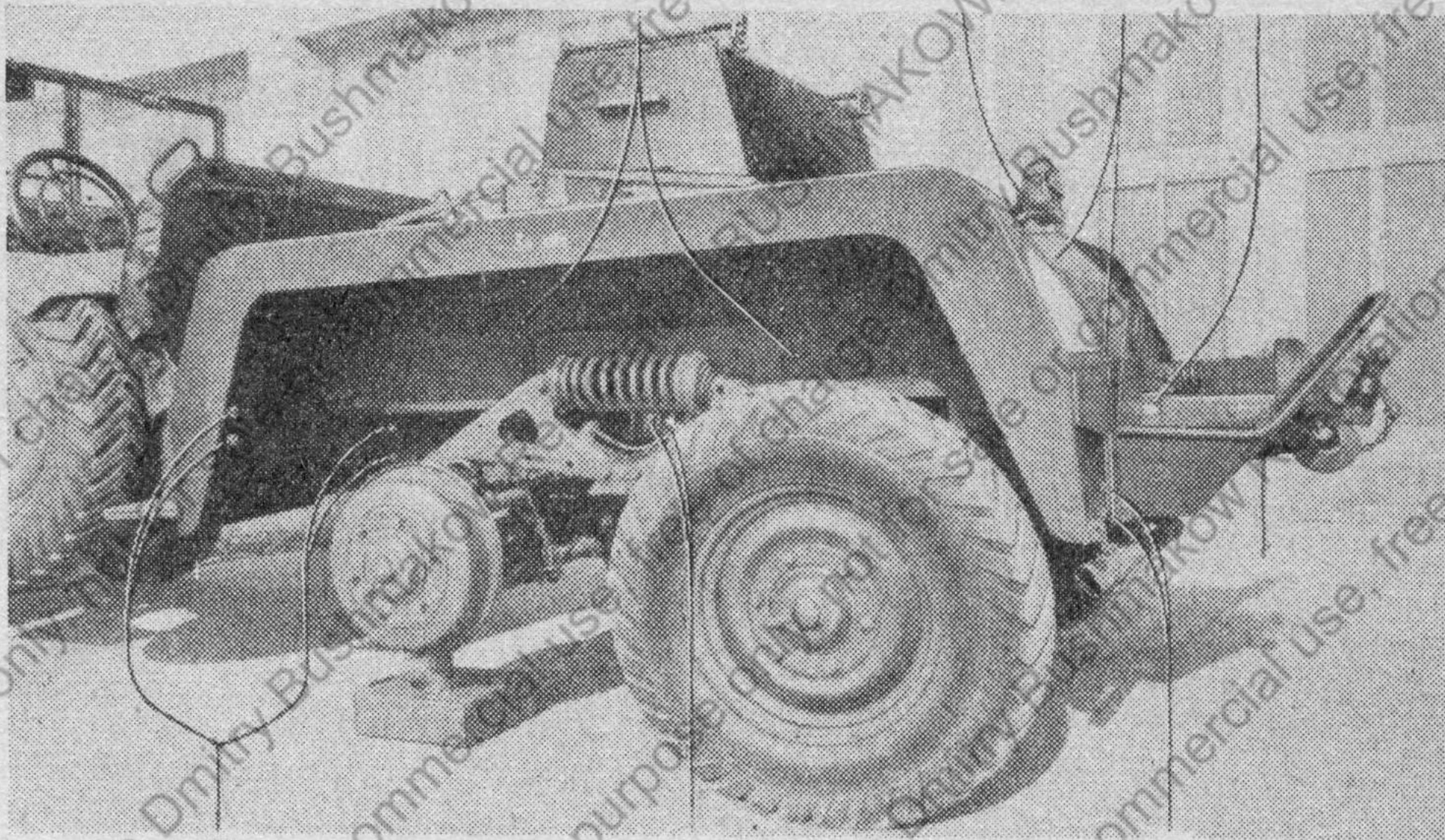
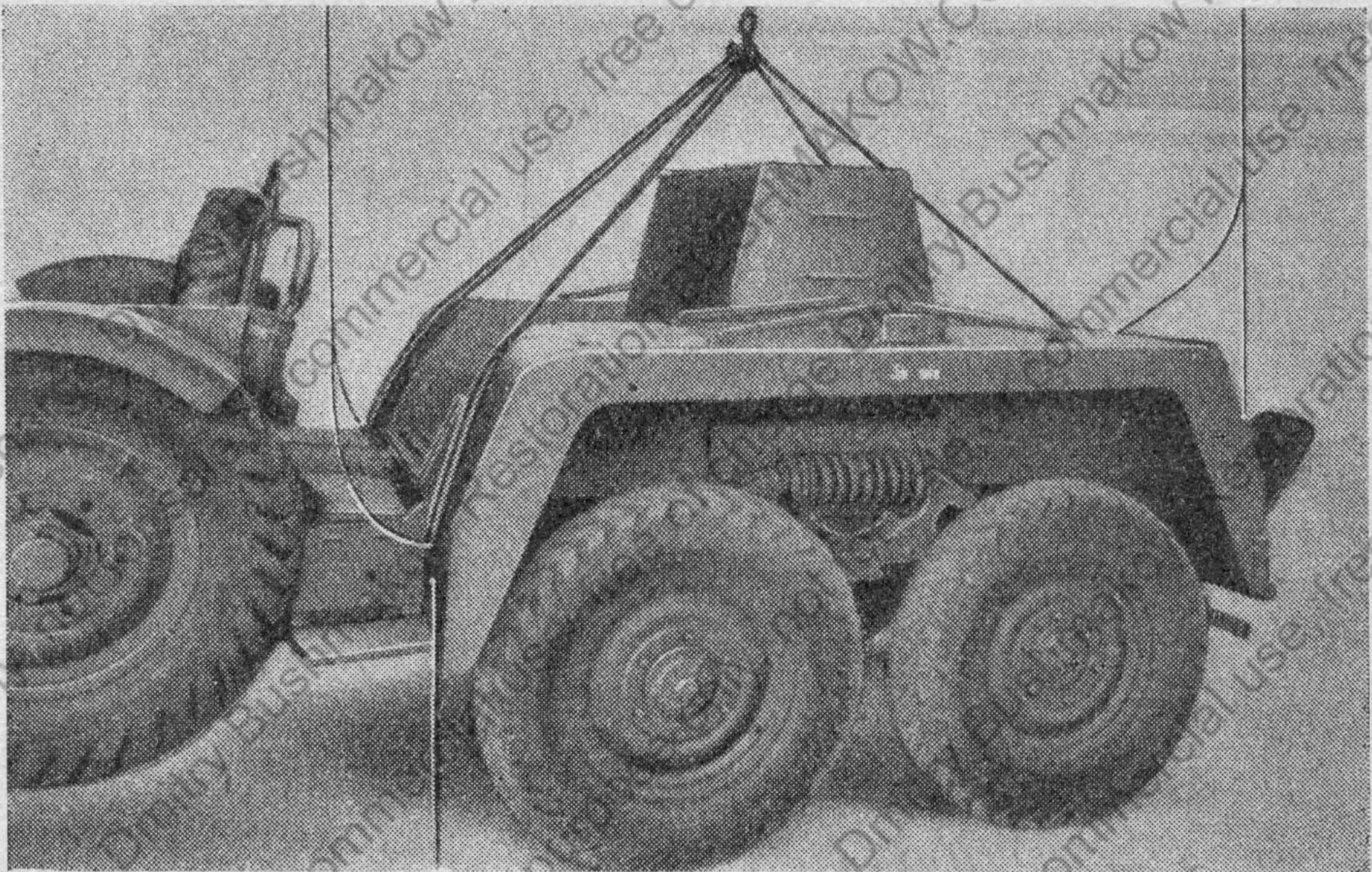

Bild 91 **Fahrersitz**

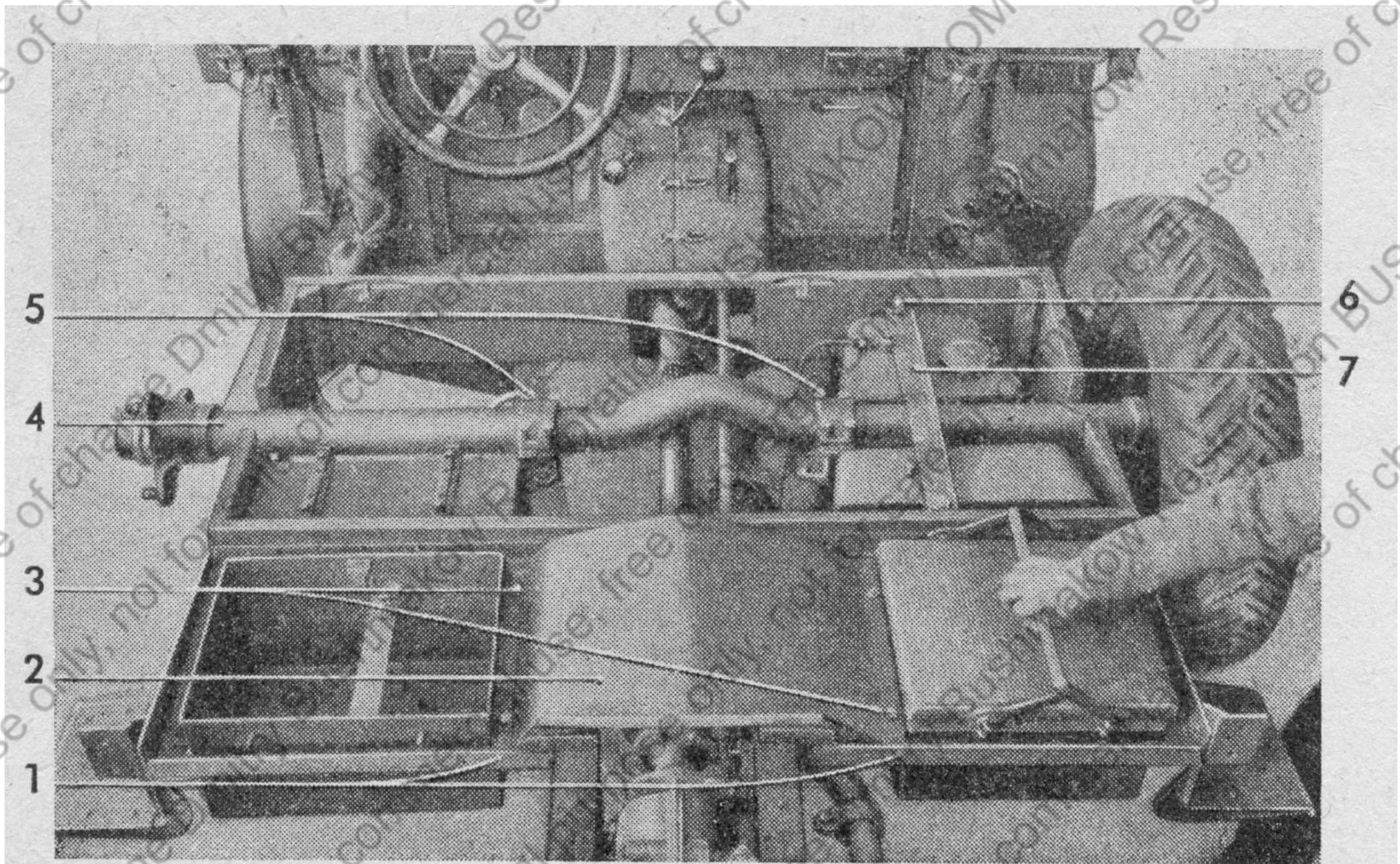

**Bild 92    Aufbauvorderteil abgenommen**



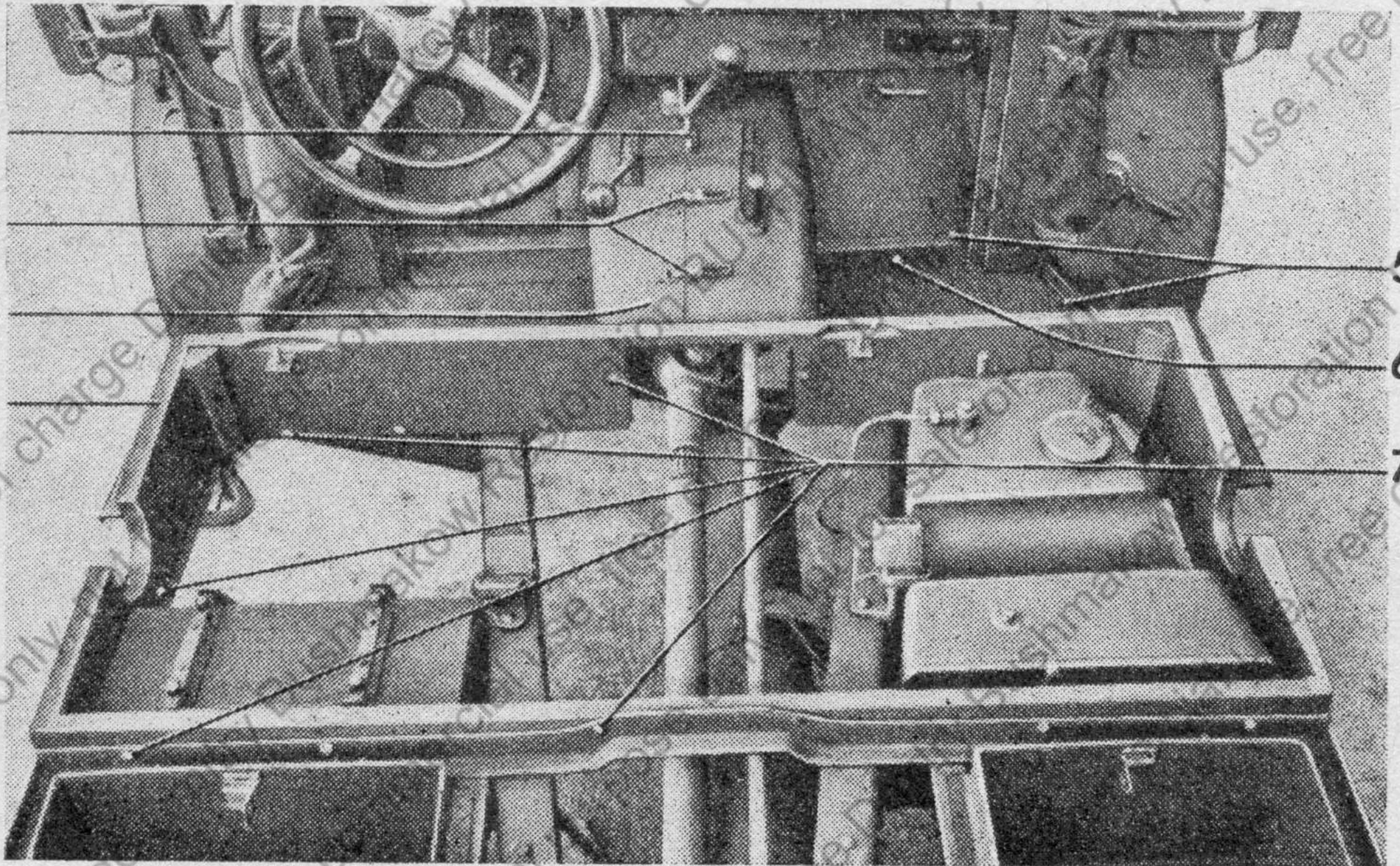

**Bild 93 Fahrersitzrahmen**

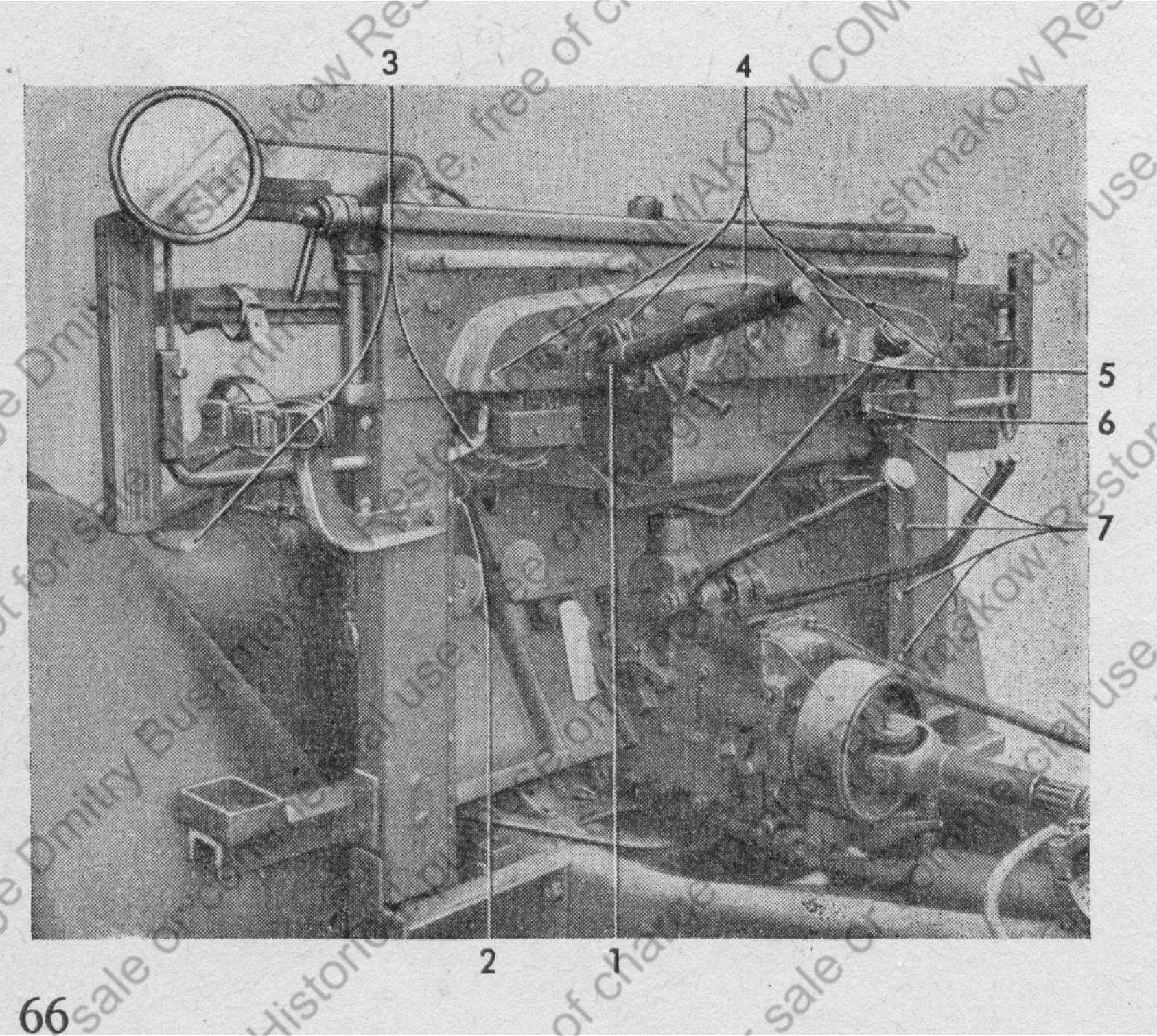

3

4

5

6

7

2

1

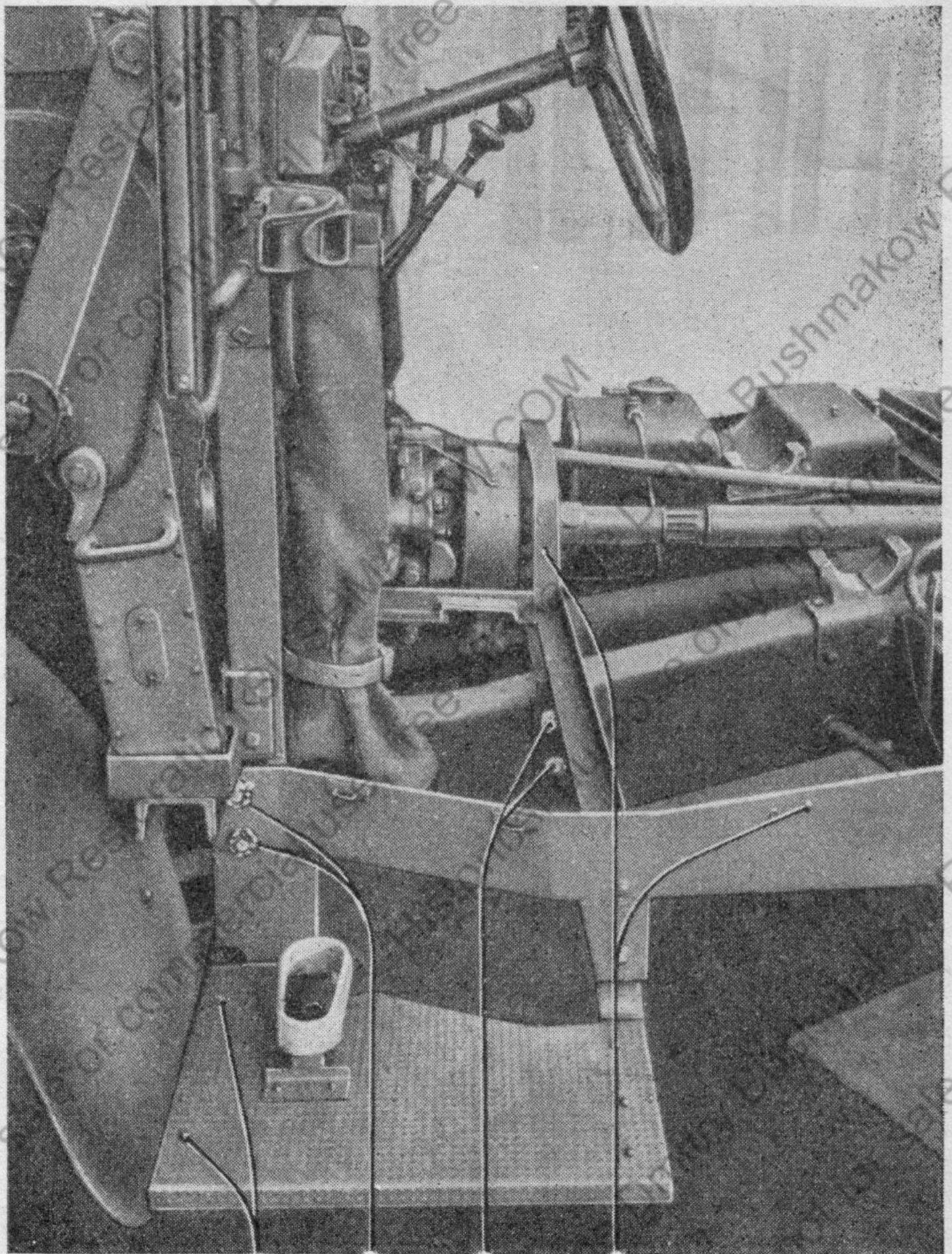

4 3 2 1

**Bild 94 Rahmen für Bodenbleche**

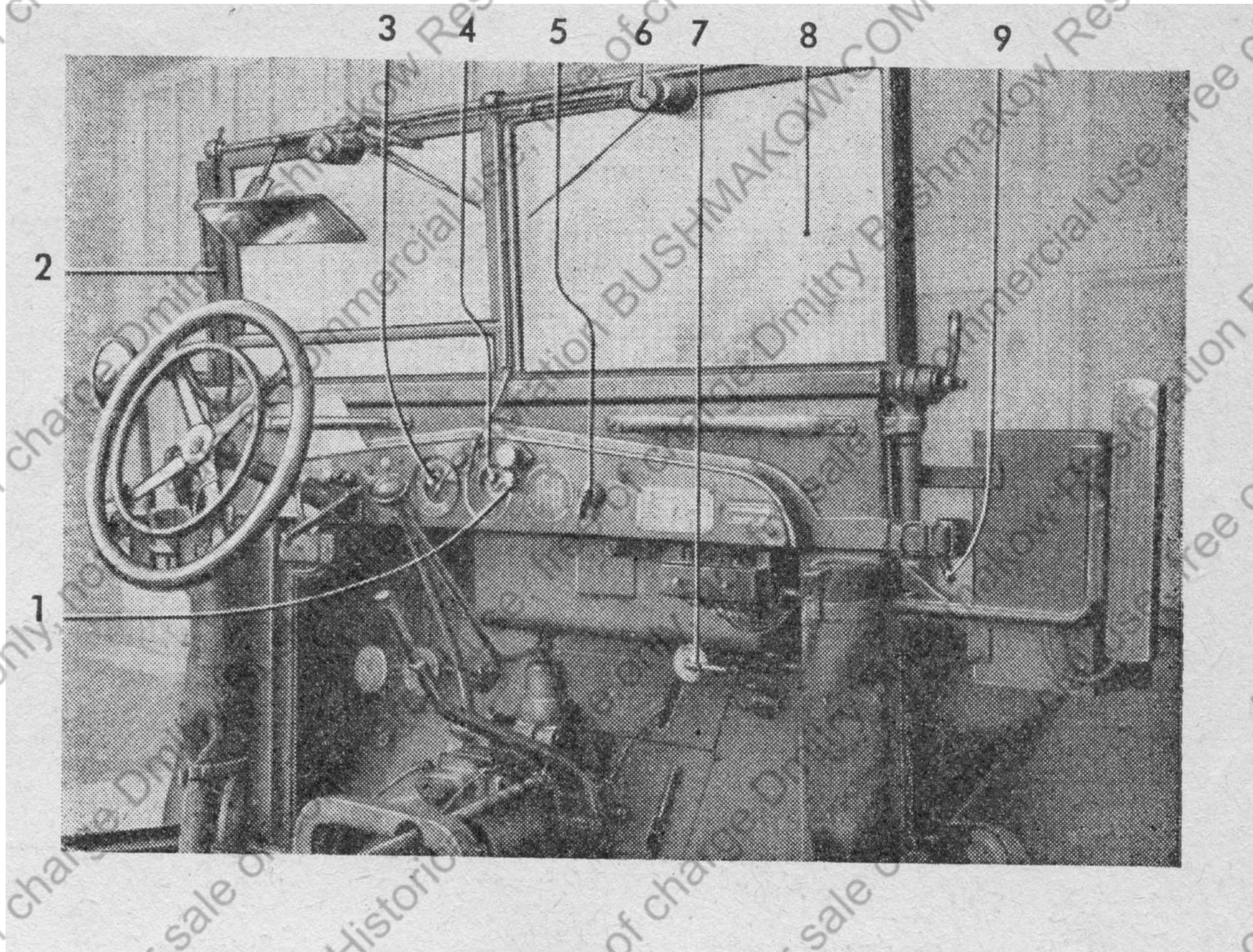

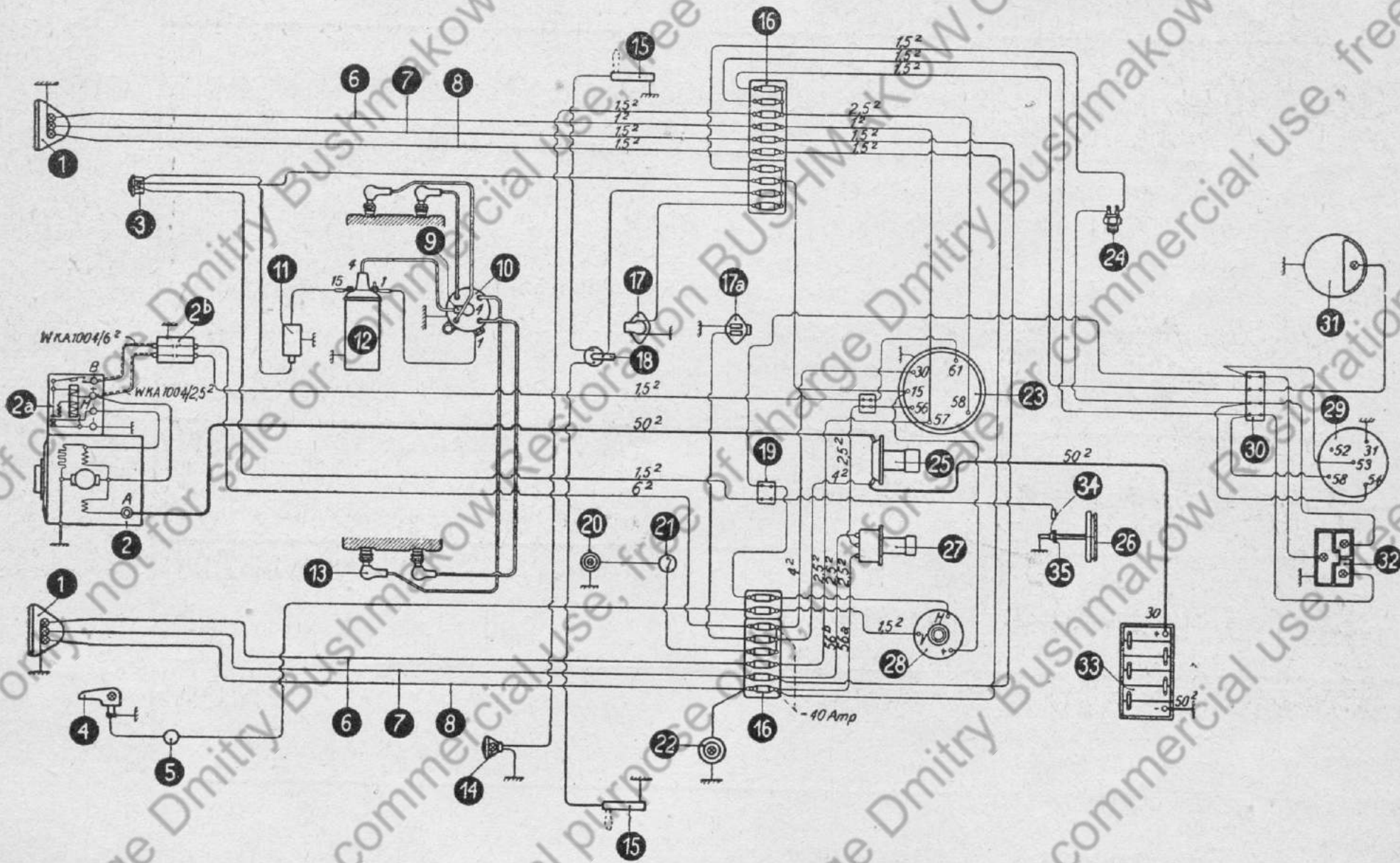

**Elektrischer Schaltplan**

1 Hauptscheinwerfer

10 Zündkerze

11

12

13

14

15

16

17

18

19

20

21

22

23

24

25

26

27

28

29

30

31

32

33

34

35

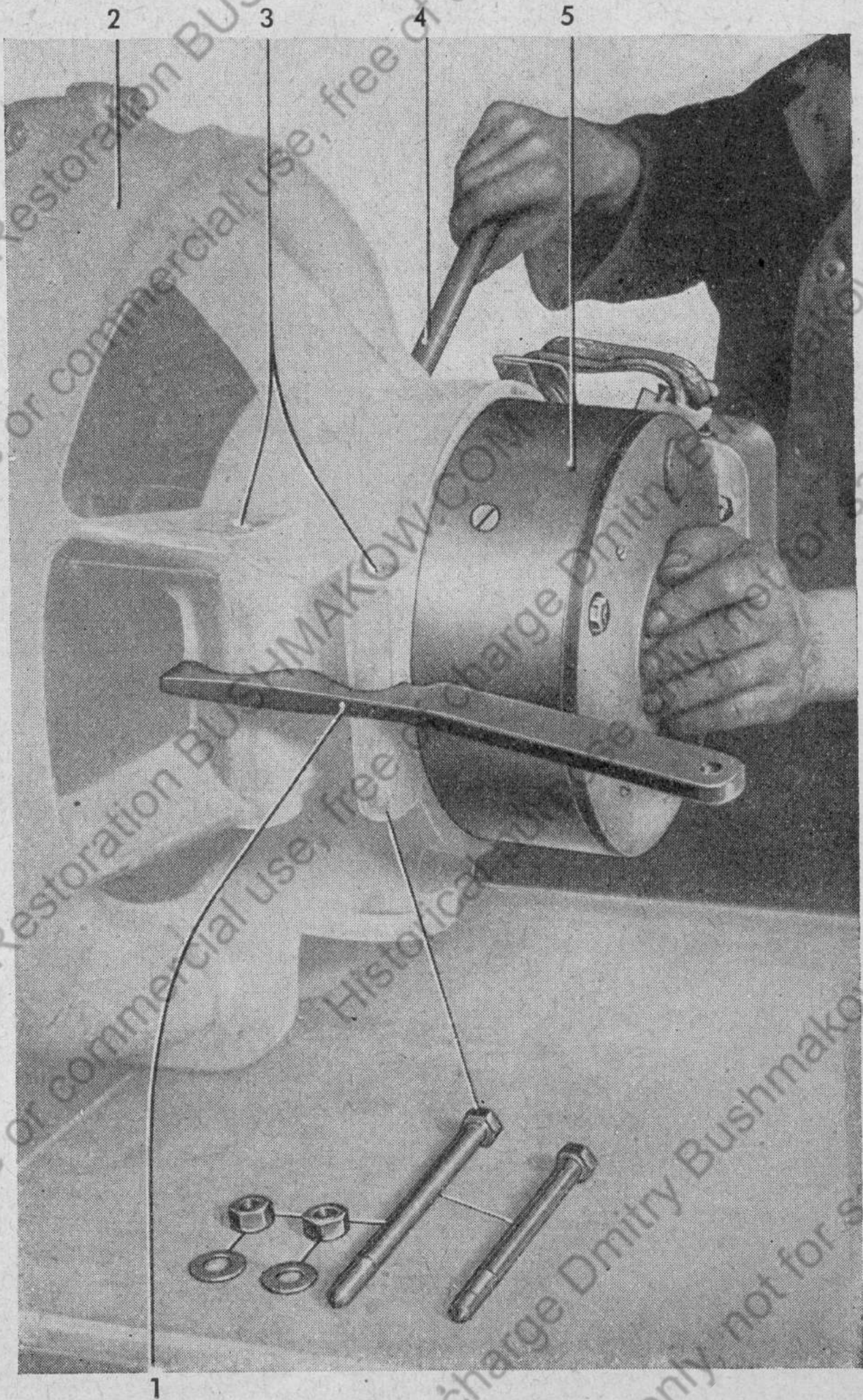

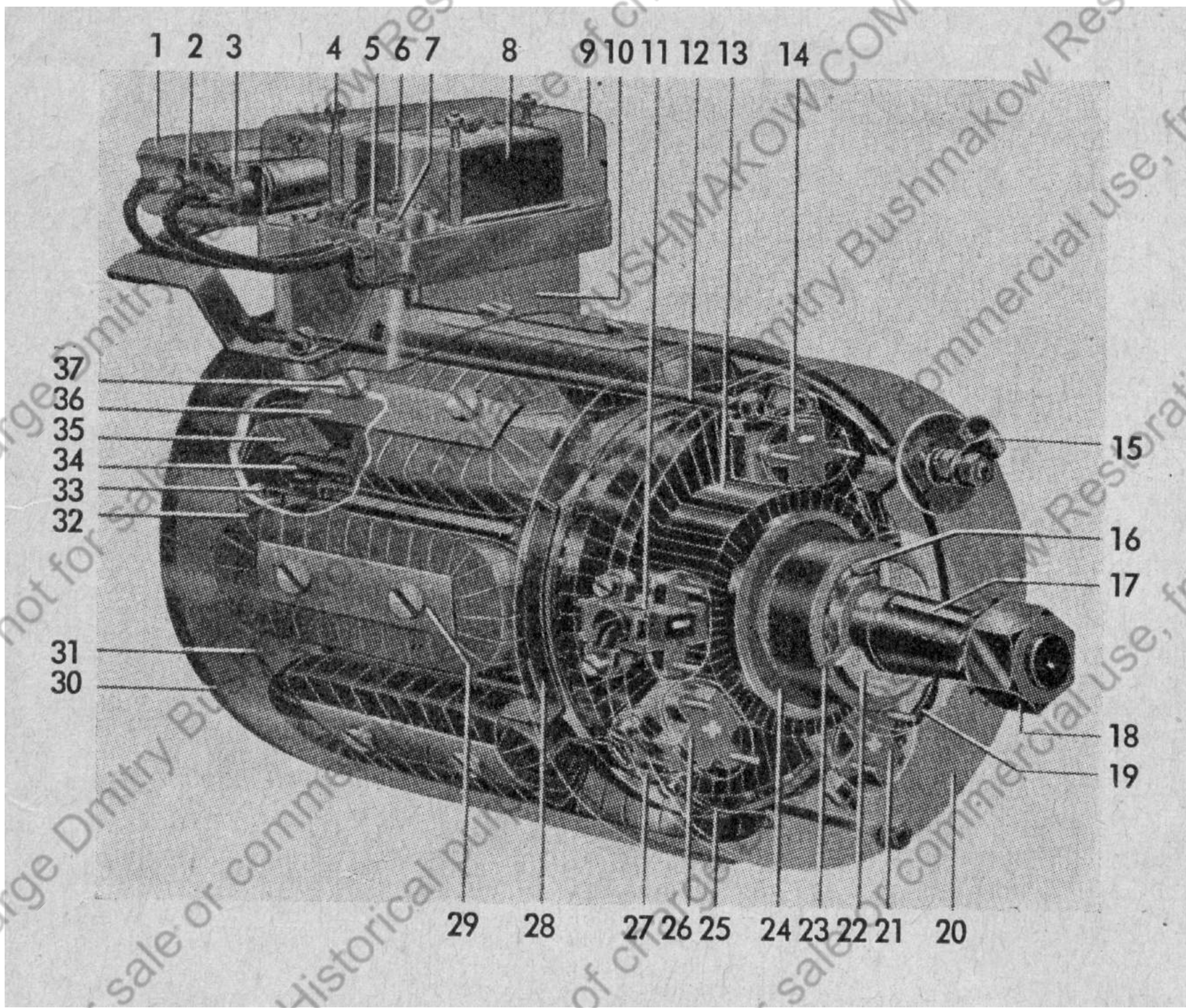

1 2 3 4 5 6 7 8 9 10 11 12 13 14

37  
36  
35  
34  
33  
32  
31  
30

15  
16  
17  
18  
19

29 28 27 26 25 24 23 22 21 20

11 12 13 14

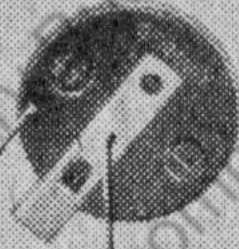
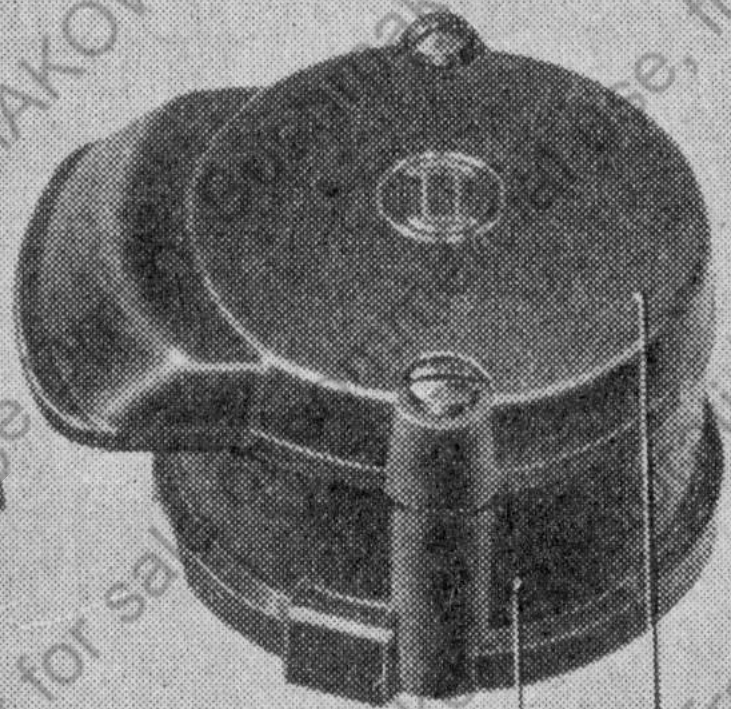
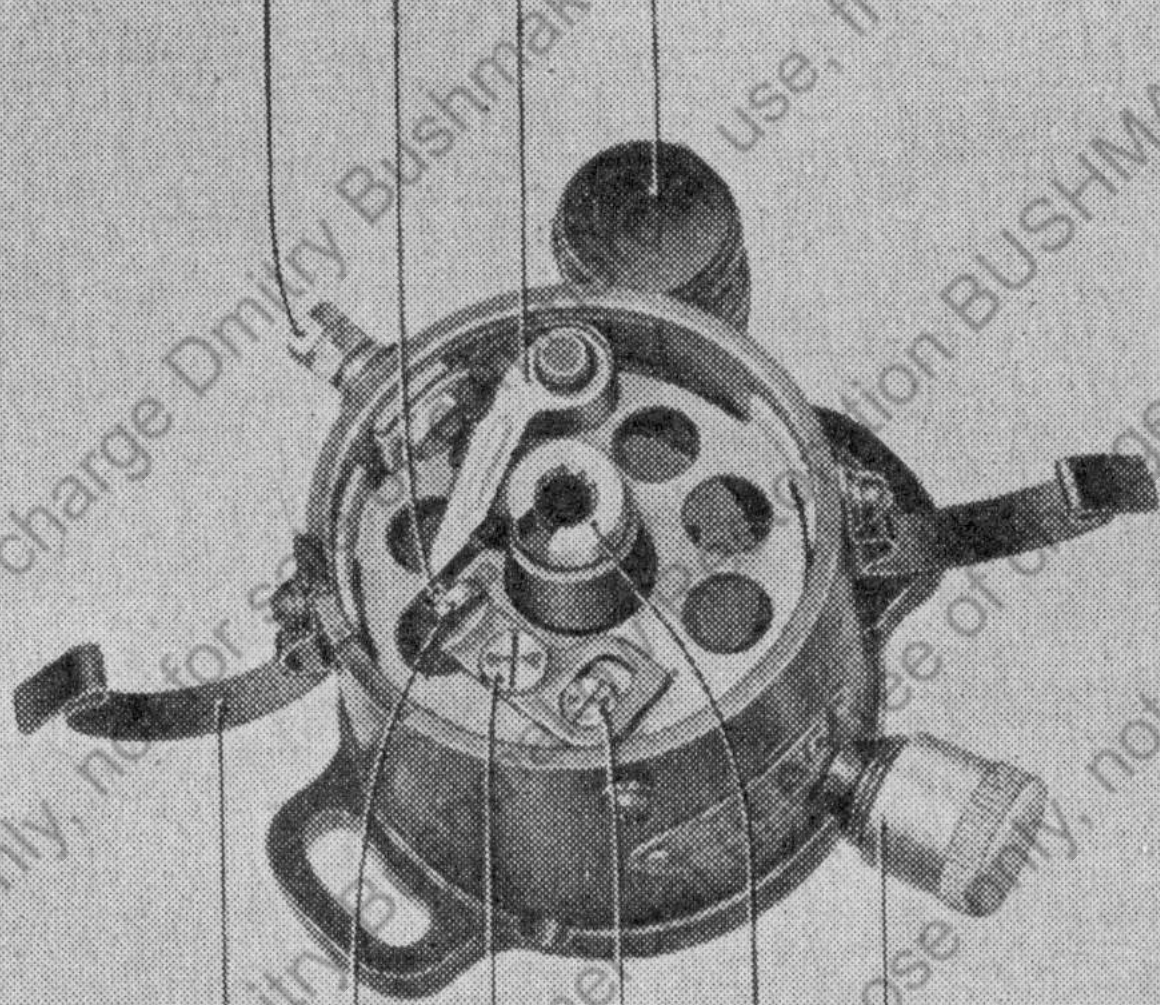

10 9 8 7 6 5 4 3 2 1



